

Assembly Instructions
Door Drive for Elevators

TSG V4

Information

Manufacturer	Langer & Laumann North America Inc.
Address	397 Pilot Drive, Suite 102 Valparaiso, IN 46383 USA
Telephone	+1 (219) 309-1200
E-Mail	support@lul-ing.com
Internet	www.lul-ing.com

Contents

1	About this manual.....	6
1.1	Purpose.....	6
1.2	Scope of application.....	6
1.3	Version information.....	6
1.4	Contact information.....	6
1.5	Target group.....	6
1.6	Presentation formats.....	6
1.7	Device information.....	7
1.8	Other applicable documents.....	7
2	Safety.....	8
2.1	General safety instructions.....	8
2.2	Intended use.....	8
2.3	Responsibility of the owner.....	8
2.3.1	Obligations of the owner.....	8
2.3.2	Owner obligations to the personnel.....	8
2.4	Employee requirements.....	9
2.4.1	Qualification and areas of activity of the employees.....	9
2.4.2	Personal protective equipment.....	9
2.5	Product-specific hazards.....	10
2.5.1	Mechanical hazards.....	10
2.5.2	Heat hazards.....	10
2.5.3	Electrical hazards.....	10
2.5.4	Risks caused by misuse.....	11
2.6	Warnings.....	11
2.6.1	Structure of the warnings.....	11
2.6.2	Meaning of the signal words and symbols.....	11
2.7	Illegible signage.....	12
3	Product description.....	13
3.1	Overview.....	13
3.2	Components.....	13
3.3	Motor position.....	15
3.4	Enclosure designs.....	15
3.4.1	TSG V4 external electronics.....	15
3.5	Dimensions.....	18

3.6	TSG V4 electronic	19
3.6.1	Interfaces and displays of the TSG V4 electronic	19
3.6.2	Technical data of the TSG V4 electronic	20
3.6.3	Power supply connection	23
3.6.4	Integrated fuses	24
3.6.5	Inputs and outputs	25
3.6.6	Motor connection	31
3.6.7	External control voltage supply	32
3.7	TSG options	33
3.7.1	TSG web interface	33
3.7.2	Emergency power supply	33
3.7.3	Light curtain	33
4	Transport and storage	35
4.1	Transport	35
4.2	Packaging	35
4.3	Storage	35
5	Mechanical mounting	36
5.1	Requirements	36
5.2	Procedure	36
5.2.1	Assembly	36
5.2.2	Mounting on the door	38
5.3	Deflection roller	38
5.4	Synchronous belt	39
6	Electric setting, parameterization and commissioning	40
6.1	Overview	40
6.2	7-segment display	40
6.3	Menu structure	42
6.4	Door learning procedure	42
6.5	Manual mode/manual travel	44
6.6	Default parameters	44
6.6.1	Basic setting	44
6.6.2	Travel profiles with default parameters	44
6.6.3	User setting of the P parameters	46
6.7	Extended parameters	47
6.7.1	Travel profiles with extended parameters	47
6.7.2	User setting of the c parameters	48
6.7.3	User setting of the b parameters	49
6.7.4	User setting of the h parameter	51
6.7.5	Mode setting with parameter hA	53
6.7.6	Error codes (E parameters)	55
6.7.7	Operating state (r parameters)	56
6.7.8	User setting of the Au parameters	57

6.8	Door force settings	58
6.8.1	Basic principles	58
6.8.2	Maximum kinetic energy	58
6.8.3	Maximum static force	58
6.8.4	Obstacle detection in closing direction.....	59
6.8.5	Obstacle detection in opening direction	59
6.9	Special functions	60
6.9.1	Holding torque in the end positions.....	60
6.9.2	Closing the door on deactivation or breakdown of the external protective device	60
6.9.3	Stop function	61
6.9.4	Leading limit switch	62
6.9.5	Mechanical transmission.....	63
7	Operation.....	64
7.1	Restart after power failure and restored utility power.....	64
7.2	Normal operation.....	64
8	Maintenance.....	65
8.1	Maintenance safety instructions.....	65
8.2	Regular checks	66
9	Troubleshooting.....	67
9.1	Troubleshooting safety instructions.....	67
9.2	Error with displayed error code	68
9.3	Error without displayed error code	72
10	Dismantling and disposal	73
10.1	Dismantling and disposal safety instructions	73
10.2	Disposal	74
11	Declaration of incorporation	75

1 About this manual

1.1 Purpose

These Assembly Instructions contain important information on the mounting, commissioning, function and maintenance of the device. Observing the manual helps to avoid hazards, repair costs and downtimes and increases the reliability and life of the device.

1.2 Scope of application

These Assembly Instructions apply to the following device: door operator TSG V4.

1.3 Version information

The issue status of these Assembly Instructions are stated on the cover page and in the footers on every page.

Always keep and use the current version of all documentation.

If an outdated version of this or the required supplementary documentation is used, this can lead to faulty mounting, commissioning or operation.

1.4 Contact information

See page 2.

1.5 Target group

This mounting manual is directed at end customers of Langer & Laumann Ing.-Büro GmbH.

In addition to reading these Assembly Instructions, the following requirements and previous technical knowledge of the user is required for correct operation of the device:

- comprehensive technical knowledge of the existing elevator systems
- knowledge of the user manuals of these elevator systems
- Classification as qualified employee

1.6 Presentation formats

The following presentation formats are used in these Assembly Instructions:

Parameter	Bold and italic print, example: <i>P8</i> .
Parameter values	Typewriter font, example: 05.
Displays	The content of the 7-segment display is presented as shown in the following examples: "nL", "RR", "o5".
Instructions	Requirements for an instruction are represented with a tick. The steps to be carried out are numbered. Results of the individual steps are marked by a black arrow. The overall result of an instruction is highlighted by a white arrow in a black circle.

Example

- ✓ Requirement
- 1. Instruction (Step 1)
- 2. Instruction (Step 2)
 - ⇒ The interim result or system response to step 2
- 3. Instruction (Step 3)
- ☞ Overall result of the instruction

Lists Lists without a compulsory order are shown as a list with bullet points (en dash).

Example

- Property A
 - Detail 1
 - Detail 2
- Property B
 - Detail 1
 - Detail 2

1.7 Device information

The most important device information is provided on the nameplate.

1.8 Other applicable documents

The following documents are required for work that is not described in these Assembly Instructions:

- Information about components not manufactured and supplied by Langer & Laumann
- Overall user manual of the elevator system

2 Safety

2.1 General safety instructions

The door drive may not be mounted, commissioned or maintained without the information in these Assembly Instructions. Before starting any work, the employees must have read through these Assembly Instructions carefully and understood it.

The safety instructions and other instructions in these Assembly Instructions and the safety instructions and danger warnings attached to the door drive must be observed.

The local accident prevention regulations and general safety provisions that apply at the place of use must be observed.

2.2 Intended use

The TSG V4 door operator is a door drive for automatic operation of horizontally or vertically moved sliding doors (vertical elevator doors).

2.3 Responsibility of the owner

2.3.1 Obligations of the owner

The owner is responsible for ensuring that the elevator system is set up, installed, operated and maintained properly.

The owner must ensure safe operation and observe the requirements listed in the user manual.

The owner is responsible for ensuring that the safety instructions listed in the [► Product-specific hazards \[p. 10\]](#) section, the local accident prevention regulations and the local environmental protection provisions are complied with at all times.

2.3.2 Owner obligations to the personnel

- The owner makes sure that only appropriately instructed and authorized employees work on the elevator system.
- Unauthorized persons must be kept away from the elevator system.
- The employees have the necessary qualification and receive the necessary training.
- The owner makes sure that no one whose ability to respond is impaired, for example, by drugs, alcohol, medication or similar, is allowed to work on the elevator system.
- The owner makes sure that the operating, maintenance and servicing employees have been thoroughly familiarized with all safety instructions and that the safety instructions are followed.
- The employees can examine the Assembly Instructions at any time. The Assembly Instructions must be kept near the elevator system.
- The owner makes sure that the employees receive and wear the specified personal protective equipment.

2.4 Employee requirements

2.4.1 Qualification and areas of activity of the employees

The tasks described in this manual set different requirements for the qualification of the assigned employees. Inadequately qualified employees are not able to correctly assess the risks and expose themselves and others to the risk of injuries. It is prohibited for inadequately qualified employees to be in the working/danger zone. Persons whose ability to respond is influenced, for example, by drugs, alcohol or medication may not work on the elevator system.

Qualified employees Work on mechanical components may only be carried out by suitably qualified employees (elevator installer for defined tasks in elevator construction according to DGUV 303-001).

Electrically qualified employees Work on electrical components may only be carried out by electrically qualified employees or elevator installers with further training as an electrically qualified person for defined tasks in elevator construction according to DGUV 303-001.

2.4.2 Personal protective equipment

Personal protective equipment is worn to protect persons from safety and health impairments during work. Wear the specified personal protective equipment.







Symbol	Meaning
	Wearing protective work clothing protects against dangers in the workplace.
	Wearing slip-resistant safety footwear protects against foot injuries.
	Wearing cut and puncture resistant protective gloves protects against hand injuries.
	Wearing a protective cap protects against head injuries.
	Wearing protective goggles protects against eye injuries.
	Wearing hearing protection protects against hearing damage.
	Wearing a fall arrest system protects against falling.

Table 1: Personal protective equipment

2.5 Product-specific hazards

2.5.1 Mechanical hazards

Moving parts can entangle and crush or bruise parts of the body.

Parts with sharp edges and pointed corners pose a risk of injury.

- Never touch moving parts.
- Keep the movement area clear of moving parts.
- Before any work on components or individual parts, disconnect TSG V4 from power supply and ensure inadvertently connection is impossible.
- Only carry out work on components if they are at a complete standstill.
- After completing the work on components, reattach all covers, threaded fasteners and safety devices immediately.
- Do not bypass, dismantle or manipulated protective devices.
- Wear the specified personal protective equipment.
- Set the parameters according to the relevant standards.

2.5.2 Heat hazards

The motor of the TSG V4 can become hot in continuous operation, thus causing a risk of burns.

- Allow the motor to cool before starting the work.
- Wear the specified personal protective equipment (suitable protective gloves).

2.5.3 Electrical hazards

Touching live parts inside the TSG V4 or in the area of the electrical equipment poses a risk to life.

- Work on the electrical installation may only be carried out by trained electrically qualified employees.
- Fuse the TSG V4 as shown on the circuit diagram.
- Only use original fuses.
- Always carry out the 5 electrical safety steps:
 - Disconnect completely
 - Secure against reconnection
 - Verify that the installation is dead
 - Carry out earthing and short-circuiting
 - Provide protection against adjacent live parts

2.5.4 Risks caused by misuse

The TSG V4 must only be used as intended. This means observing all instructions in this Assembly Instructions in every stage of the life cycle.

Misuses are, for example:

- Carrying out work without adequate qualification/technical knowledge and without instruction
- Structural changes not planned by the manufacturer
- Use of unapproved additional equipment
- Bypassing/removing protective devices
- Commissioning a damaged or non-functional device

2.6 Warnings

2.6.1 Structure of the warnings

All warnings in this document are structured as follows:

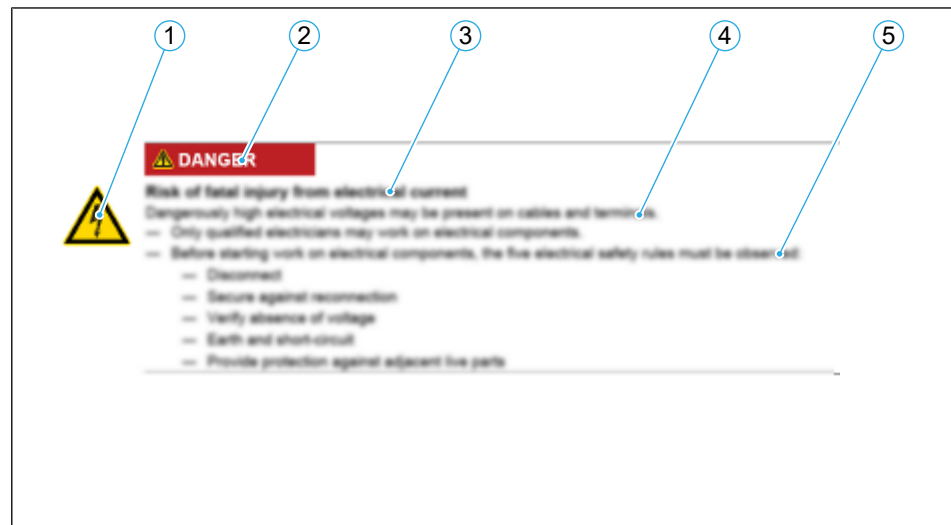

1	Danger symbol	2	Signal word
3	Type and source of the danger	4	Possible consequences of disregard
5	Procedure to prevent danger		

2.6.2 Meaning of the signal words and symbols

The following signal words are used in this document:

Signal word	Meaning, consequences if not prevented
DANGER	Warns of an imminent hazardous situation which results in death or serious injury.
WARNING	Warns of a potential hazardous situation, which could result in death or serious injury.
CAUTION	Warns of a potential hazardous situation, which could result in minor or moderate injury.

Signal word	Meaning, consequences if not prevented
ATTENTION	Warns of a hazardous situation, which can result in material damage or environmental damage.

Table 2: Meaning of the signal words

The following danger-specific symbols are used in this document:





Symbol	Designation
	Automatic start-up
	Electrical hazard
	Gear wheels
	General warning
	Hot surface

Table 3: Meaning of the danger-specific symbols

2.7 Illegible signage

During the course of time, labels and signs can become dirty or unrecognizable/ illegible in some other way so that dangers are not recognized and necessary operating instructions cannot be followed. To avoid injuries, all warnings must be kept in a good, legible condition at all times. Damaged signs or labels must be renewed immediately.

3 Product description

3.1 Overview

The TSG V4 door operator is a door drive for automatic operation of horizontally or vertically moved sliding doors (vertical elevator doors). Langer & Laumann does not accept any liability for applications outside the defined application. The speeds and accelerations can be adjusted. The door opening is determined by a measurement process.

When operated as a power operated guard, the door operator TSG V4 meets the requirements of EN 81-20 with category 2.

The TSG V4 can be used for up to approx. 20,000 mm travel distance. The door panel weights in the standard configuration must not exceed 400 kg. Speed increases or reductions at the synchronous belt change the kinetic and static forces, see ▶ [Mechanical transmission \[p. 63\]](#).

3.2 Components

The following figure shows the assembled mechanical components of the device by way of example.

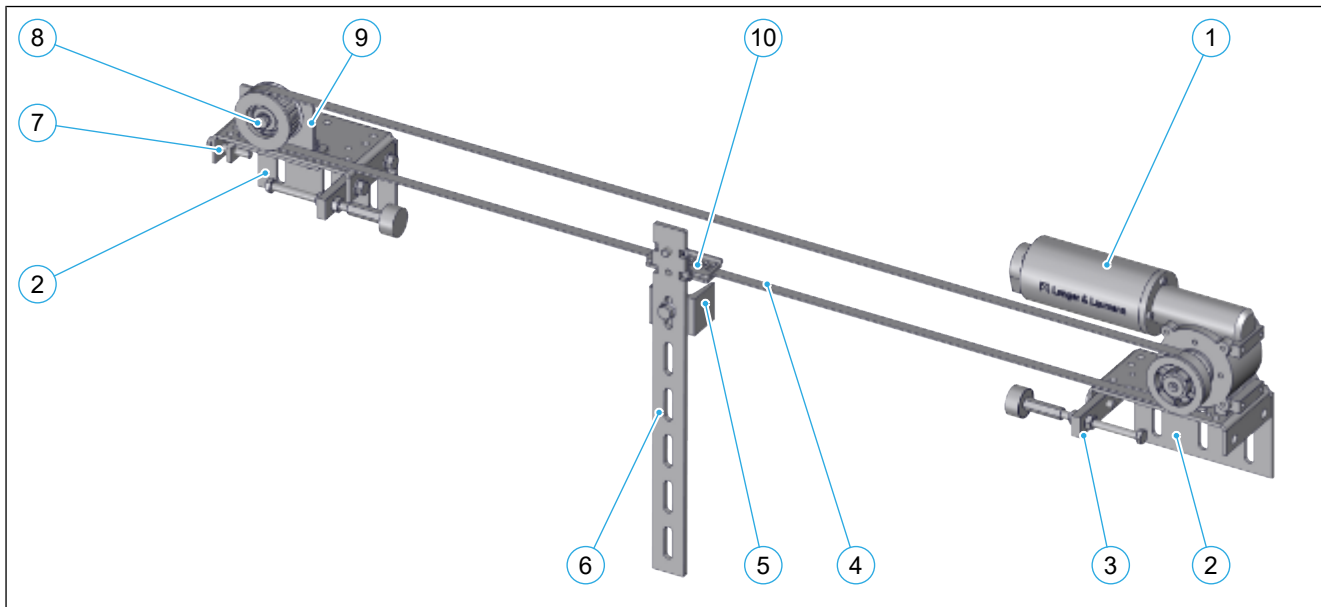



III. 1: Example TSG assembly

Item	Part number	Designation
1	8.20.40000.X1	TSG drive (here: left version)
2	1.20.60040	TSG angled bracket, standard
3	1.20.60030	TSG stop set (incl. buffer)
4	1.20.xxxxx	Synchronous belt
5	1.20.60020	TSG stop on the door panel adapter
6	1.20.60004	TSG door panel adapter
7	1.20.60110	TSG mounting link
8	1.20.60003	TSG deflection roller
9	1.20.60013	TSG bracket for deflection roller
10	1.20.60005	TSG synchronous belt lock

3.3 Motor position

The TSG drive is available with two different motor positions. The motor position is independent of the opening direction or the opening method of the door to be moved. The TSG drive with output left can, for example, be installed on the right or left-hand side.

<p>Motor output position left When looking at the gear head with the foot mounting at the bottom, the output is on the left-hand side.</p>	
<p>Motor output position right When looking at the gear head with the foot mounting at the bottom, the output is on the right-hand side.</p>	

3.4 Enclosure designs

The TSG V4 electronics are available in the following enclosure designs:

- TSG V4-External electronics

3.4.1 TSG V4 external electronics

This enclosure design is splash-proof and is fixed in a suitable position near the TSG drive with four screws.

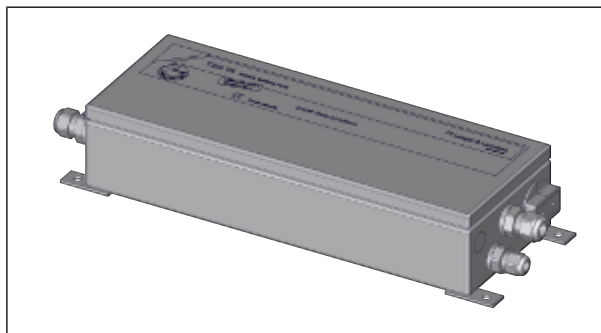

III. 2: Front view of the TSG V4 external electronics

Cable entry The cables can be optionally fed in through the left or right side with cable glands through prepunched holes in the housing. The motor and encoder cables use a common dividable cable gland.

ATTENTION

Possible damage

- On opening the prepunched hole, make sure that the TSG V4 electronics are not damaged and no metal parts get on them.
- Close off all broken out openings using the threaded fasteners provided in order to main the degree of protection.

Dimensional and assembly drawings

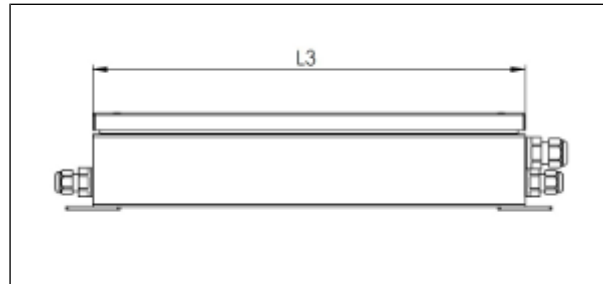

III. 3: Long side view with dimensions of the TSG V4 external electronics

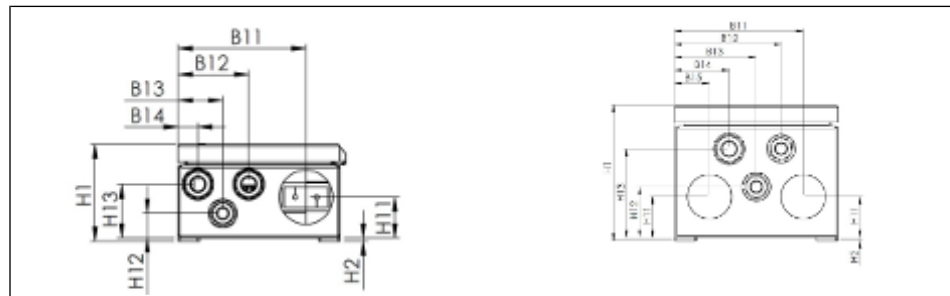

III. 4: Narrow side view with dimensions of the TSG V4 external electronics (in two different available heights)

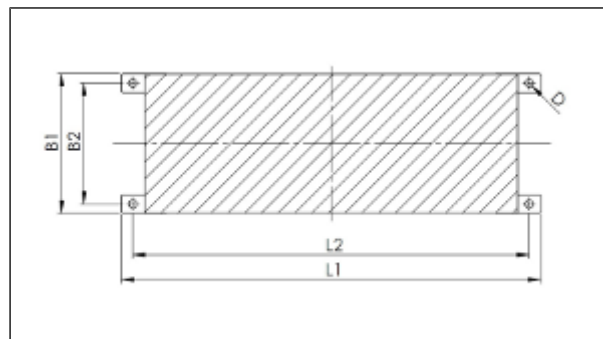

III. 5: Plan view with dimensions of the TSG V4 external electronics

Dimensions and weight

Property	Abbreviation	Value at H1 = 88 mm	Value at H1 = 125 mm
Housing length	L3	400 mm	
Total length	L1	425 mm	
Total width	B1	150 mm	
Distance between mounting holes	B2	130 mm	
Mounting hole diameter	D	8.5 mm	
Total height	H1	88 mm	125 mm
Height of fastening lugs	H2	3 mm	3 mm
Height of hole, cable gland 1	H11	36 mm	38 mm
Height of hole, cable gland 2	H12	21 mm	47 mm
Height of hole, cable gland 3 and 4	H13	48 mm	82 mm
Hole distance, cable gland 1	B11	121 mm	118 mm
Hole distance, cable gland 2	B12	68 mm	98 mm
Hole distance, cable gland 3	B13	44 mm	75 mm
Hole distance, cable gland 4	B14	21 mm	50 mm
Hole distance, cable gland 5	B15		32 mm
Weight	approx. 4.1 kg...5.8 kg (depending on the equipment)		

Table 4: Dimensions and weight of the TSG V4 external electronics

Cable gland	Cable diameter
M16	5 mm...10 mm
M20	8 mm...13 mm

Table 5: Cable diameters and cable glands of the TSG V4 external electronics

3.5 Dimensions

The following figures show the most important dimensions of the mechanical part of the door drive.

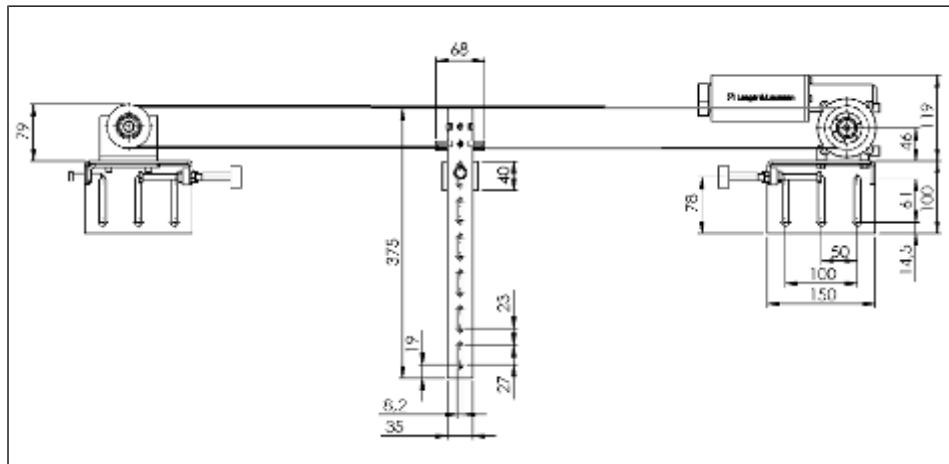

III. 6: Dimensioning of the door drive's mechanics (front view) (all dimensions in mm)

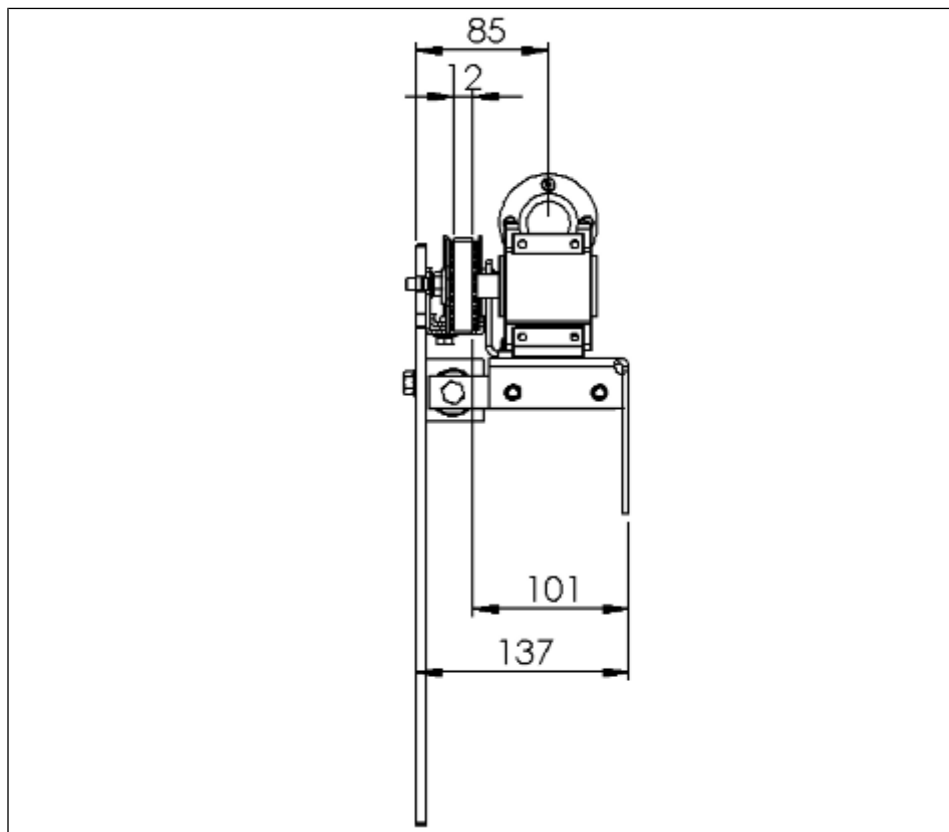

III. 7: Dimensioning of the door drive's mechanics (side view) (all dimensions in mm)

3.6 TSG V4 electronic

3.6.1 Interfaces and displays of the TSG V4 electronic

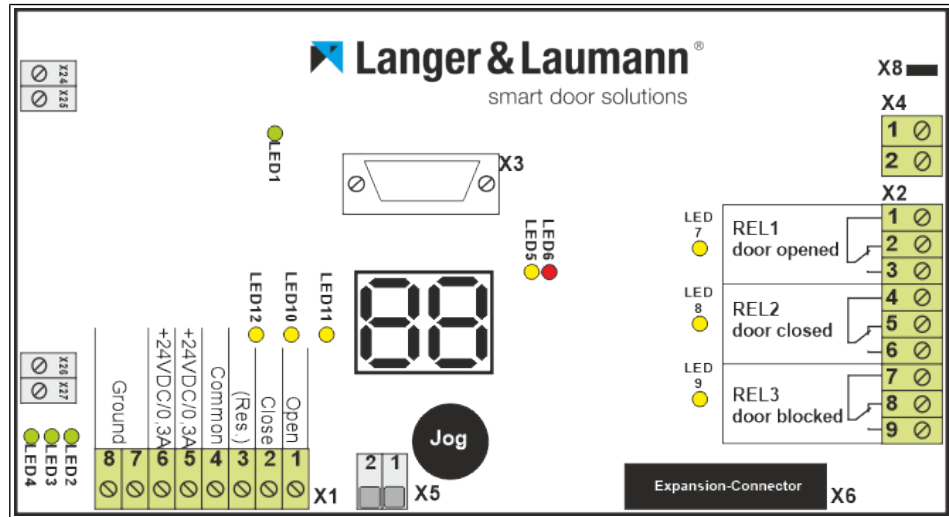

III. 8: Position of the interfaces and displays of the TSG V4 electronics

Designation	Meaning
X1	Inputs
X2	Outputs
X3	Motor encoder
X4	Motor
X5	Stop input (see also ▶ Connection for the stop function (X5) [p. 30])
X6	Expansion connector
X8	Motor shield
X24/25	Internal power supply
X26/27	Internal power supply

Table 6: Interfaces of the TSG V4 electronics

Designation	Meaning
LED 1	Operating voltage 38 VDC
LED 2	Operating voltage 5 VDC
LED 3	Operating voltage 12 VDC
LED 4	Operating voltage 24 VDC
LED 5	Check LED
LED 6	Overload
LED 7	"Door is open" output signal
LED 8	"Door is closed" output signal
LED 9	"Door is blocked" output signal
LED 10	"Close door" input signal
LED 11	"Open door" input signal
LED 12	Input signal (reserve)

Table 7: Displays of the TSG V4 electronics

3.6.2 Technical data of the TSG V4 electronic

Property	Value
Connection voltage (input characteristics)	
115 V version	
Connection voltage	115 VAC \pm 15 % (L, N, GRD)
Power consumption	1.8 A
Number of phases	1 (AC)
Frequency	50/60 Hz
Short-circuit current	4.0 A (integrated fuses)
200 V version	
Connection voltage	200 VAC \pm 15 % (L, N, GRD)
Power consumption	1.1 A
Number of phases	1 (AC)
Frequency	50/60 Hz
Short-circuit current	2.0 A (integrated fuses)
230 V version	
Connection voltage	230 VAC \pm 15 % (L, N, GRD)
Power consumption	0.9 A
Number of phases	1 (AC)
Frequency	50/60 Hz
Short-circuit current	1.25 A (integrated fuses)

Property		Value
400 V version		
	Connection voltage	400 VAC \pm 10 % (L1, L2, GRD)
	Power consumption	0.5 A
	Number of phases	2 (AC)
	Frequency	50/60 Hz
	Short-circuit current	1.25 A (integrated fuses)
480 V version		
	Connection voltage	480 VAC \pm 10 % (L1, L2, GRD)
	Power consumption	0.4 A
	Number of phases	2 (AC)
	Frequency	50/60 Hz
	Short-circuit current	1.25 A (integrated fuses)
Motor connection (X4, output characteristics)		
	Voltage range	0 VDC...38 VDC
	Current	2.5 A
	Peak current	12 A
	Number of phases	2
	Frequency	16 kHz
Fusing on site		
	115 V version	10 A, tripping characteristic B or C
	200 V version	10 A, tripping characteristic B or C
	230 V version	10 A, tripping characteristic B or C
	400 V version	5 A per phase, tripping characteristic B or C
	480 V version	5 A per phase, tripping characteristic B or C
Power consumption at rest , without applied input signal, not in the end position		approx. 3 W
Maximum power consumption		
	115 V version	1.8 A
	200 V version	1.1 A
	230 V version	0.9 A
	400 V version	0.5 A
	480 V version	0.4 A
Depending on the door weight and parameter setting, short-term (< 1 s) higher currents can flow.		
Allowable storage/transport temperature		-20 °C...+60 °C
Maximum change		20 K/h
Allowable average ambient operating temperature (for nominal data, no direct sunshine)		-20 °C...+60 °C

Property		Value
Installation altitude		Up to 1000 m above sea level without limitation 1000 m to 2000 m above sea level with reduced performance
Degree of protection		
	TSG V4-External electronics	IP54
Ambient requirements		
	Overvoltage category	III
	Pollution degree	2
	Relative humidity	10 %...90 %, noncondensing

Table 8: Technical data of the TSG V4 electronics

The TSG V4 electronics are suitable for use in an electric circuit that can supply no more than 5000 A_{RMS} at maximum 480 V, if this is protected by a circuit-breaker with an interrupting rating of not less than 10,000 A_{RMS} at maximum 480 V.

For use in the USA: integrated semi-conductor short-circuit protection does not provide any protection for branch cables. The branch circuit must be protected in compliance with the manufacturer's instructions, the National Electrical Code and additional local regulations.

For use in Canada: integrated semi-conductor short-circuit protection does not provide any protection for branch cables. The branch circuit must be protected in compliance with the Canadian Electrical Code, Part I.

3.6.3 Power supply connection

The TSG V4 is available in different input voltages. Please review the voltage stated on the product nameplate prior to connection. The image below shows the location of the external power input plug.

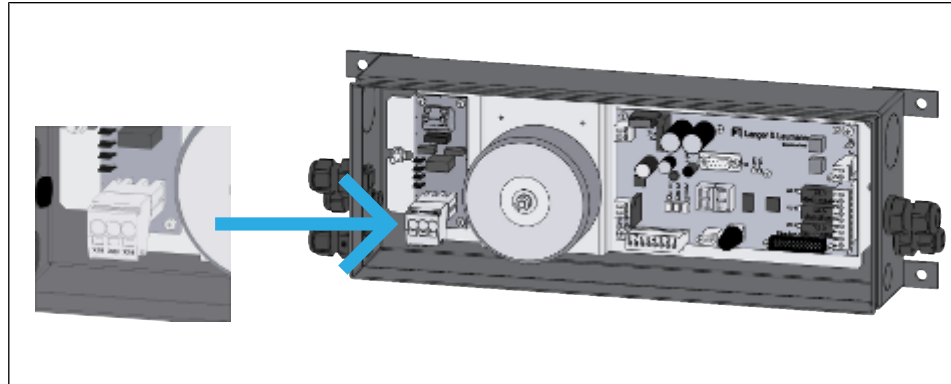

III. 9: Power supply connection of the TSG V4 external electronics

DANGER



Danger of death from electric shock

Dangerously high electric voltages are applied to terminals X18 and X19 inside the device.

- Work on electrical components may only be carried out by electrically qualified employees.
- Before starting any work on the electrical components, complete the five electrical safety steps:
 - Disconnect completely
 - Secure against reconnection
 - Verify that the installation is dead
 - Carry out earthing and short-circuiting
 - Provide protection against adjacent live parts

Pin	Assignment	
115 V version		
X18	L	115 VAC ±15 % 50/60 Hz
X19	N	
X20-GRD	GRD	Protective conductor connection
200 V version		
X18	L	200 VAC ±15 % 50/60 Hz
X19	N	
X20-GRD	GRD	Protective conductor connection
230 V version		
X18	L	230 VAC ±15 % 50/60 Hz
X19	N	

Pin	Assignment	
X20-GRD	GRD	Protective conductor connection
400 V version		
X18	L1	400 VAC ±15 % 50/60 Hz
X19	L2	
X20-GRD	GRD	Protective conductor connection
480 V version		
X18	L1	480 VAC ±15 % 50/60 Hz
X19	L2	
X20-GRD	GRD	Protective conductor connection

Table 9: Terminal assignment of the power supply connection

Version	3-pin connector with push-in spring connection
Rigid/flexible conductor cross-section (min./max.)	1.5 mm ² /2.5 mm ²
Stripped length	10 mm
Flexible conductor cross-section with wire end ferrule with/without plastic sleeve (min./max.)	1.5 mm ² /2.5 mm ²
AWG conductor cross-section (min./max.)	15/12

Table 10: Connection data of the power supply connection

Use copper cables only for the connection. For UL-compliant operation, design the cable insulation for a maximum temperature of 60 °C.

3.6.4 Integrated fuses

Designation	Function	Fusing
SI2	Control section fuse (18 VAC)	4 A
SI3	Power section fuse (26 VAC)	15 A
SI200	Blade fuse, emergency power supply power section (only equipped with battery charging circuit)	5 A

Table 11: Fuses of the TSG V4 electronics

Fuses SI2 and SI3 are not replaceable. If they blow, it is only possible for the TSG V4 electronics to be replaced by Langer & Laumann.

3.6.5 Inputs and outputs

3.6.5.1 Signal inputs (X1)

Connection of the signal inputs (X1)

The inputs for the "Open door" (X1.1), "Close door" (X1.2) and Reserve (X1.3) input signals are connected with a (nominal) voltage of 24 VDC. All inputs have a common potential, i.e., the same voltage must always be applied to all three inputs.

Pin	Assignment	
X1.1	"Open door" input signal	16 VDC...28 VDC, min. 10 mA
X1.2	"Close door" input signal	16 VDC...28 VDC, min. 10 mA
X1.3	Input signal (reserve)	16 VDC...28 VDC, min. 10 mA
X1.4	Counter potential for input signals	(Common)
X1.5	Auxiliary voltage output + Can only be used to control the TSG input signals X1.1, X1.2 and X1.3.	24 VDC \pm 20 % — limited voltage — not stabilized — fluctuates with the utility power voltage — 300 mA max load capacity
X1.6	Auxiliary voltage output + For the supply of external devices. X1.6 is switched off in emergency power mode.	24 VDC \pm 20 % — limited voltage — not stabilized — fluctuates with the utility power voltage — 300 mA max load capacity
X1.7	Auxiliary voltage output –	0 VDC
X1.8	Auxiliary voltage output –	0 VDC

Table 12: Terminal assignment of the signal inputs (X1)

The following table shows the connection and wiring options for the input signals X1.1 and X1.2.

<p>With internal 24-VDC power supply</p>	
<p>With external 24-VDC power supply and common plus</p>	
<p>With external 24-VDC power supply and common minus</p>	

Table 13: Connection options for the input signals

Version	8-pin connector with push-in spring connection
Rigid/flexible conductor cross-section (min./max.)	0.2 mm ² /2.5 mm ²
Stripped length	10 mm
Flexible conductor cross-section with wire end ferrule with/without plastic sleeve (min./max.)	0.25 mm ² /2.5 mm ²
AWG conductor cross-section (min./max.)	24/12
2 conductors with the same cross-section, flexible with TWIN-AEH with plastic sleeve (min./max.)	0.5 mm ² /1.5 mm ²
AWG according to UL/CUL (min./max.)	26/12

Table 14: Connection data of the signal inputs (X1)

Use copper cables only for the connection. For UL-compliant operation, design the cable insulation for a maximum temperature of 60 °C.

ATTENTION

Possible damage

The auxiliary voltage output at X1.5/X1.6 may not be connected to an external voltage potential. If an external voltage potential is connected to X1.5/X1.6, this can irreparably damage the device.

Standard operation of the signal inputs (X1)

In this mode, a signal applied to the respective input (X1.1, X1.2 or X1.3) is executed as long as it is applied. If the input signal is removed, the command is no longer executed.

If an input signal is applied to the two inputs X1.1 and X1.2 at the same time, then the door is opened.

If the door is to be completely opened or closed, the corresponding signal must be applied until the corresponding relay output (X2) is set.

Standard operation of the signal inputs is active if parameter **h1** is set to 00.

Pulsed operation of the signal inputs (X1)

In this mode, a pulse at least 0.2 seconds long triggers the required action at the respective signal input.

Pulsed operation of signal inputs X1.1 and X1.2 is active if parameter **h1** is set to **02**, **03** or **04**. Signal input X1.3 cannot be changed to pulsed operation and remains in standard operation.

Variation 1 Variant 1 enables pulsed operation at inputs X1.1 and X1.2. To select variation 1, set parameter **h1** to **02**.

If the closing force limitation triggers during closing the door stops. If it is to continue closing, the subsequent closing must be retriggered by a pulse at input X1.2. If automatic reversing is set (parameter **b4** = **on**), the door opens completely. A new pulse must then be applied at input X1.2 to close the door.

If input X1.3 triggers reversing during closing, the subsequent closing must be retriggered by a pulse at input X1.2.

The following figure uses an example to show how the door is controlled over time by the application of pulses at inputs X1.1 and X1.2.

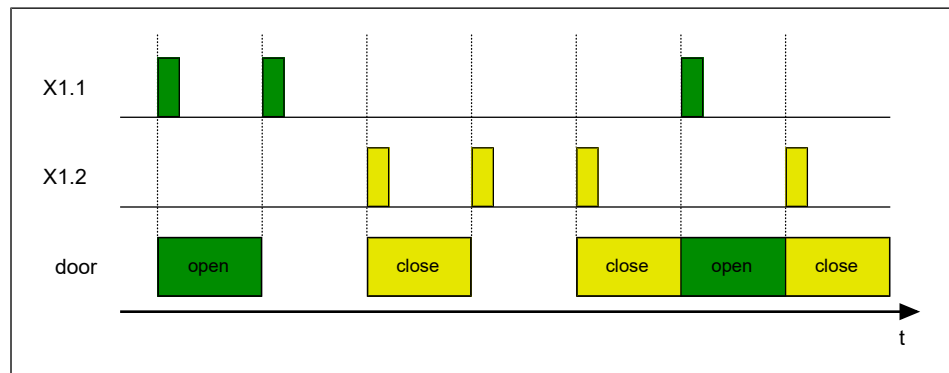

III. 10: Pulsed operation time sequence (variant 1)

Variante 2 Variante 2 enables pulsed operation at input X1.1, input X1.2 is deactivated. After the time set in parameter **h5**, the door is closed automatically in compliance with the closing force limitation set.

If the closing force limitation triggers during closing, the door stops. The closing starts again after around five seconds. If automatic reversing is set (parameter **b4 = on**), the door opens completely. The following closing is retriggered after the time set in parameter **h5** has expired.

If the door was opened by a pulse the remaining time in the open position is shown in the display.

If input X1.3 triggers reversing during closing, the following closing is triggered again after the time in parameter **h5** has expired. If the time set in parameter **h5** has expired and input X1.3 continues to trigger, then the door remains stopped in the open position until input X1.3 releases the door again.

The following figure uses an example to show how the door is controlled over time by the application of pulses at input X1.1.

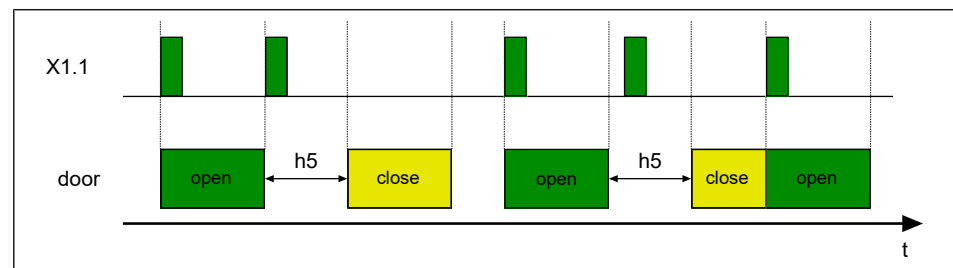

III. 11: Pulsed operation time sequence (variant 2)

3.6.5.2 Relay outputs (X2)

Three relay outputs, each with a changeover contact, are present on the TSG V4 electronics in order to display or signal the door statuses. The contacts are located on terminal block X2.

Pin	Assignment
X2.1	"Door open" output signal, potential supply
X2.2	"Door open" output signal, break contact
X2.3	"Door open" output signal, make contact
X2.4	"Door closed" output signal, potential supply
X2.5	"Door closed" output signal, break contact
X2.6	"Door closed" output signal, make contact
X2.7	"Door blocked" output signal, potential supply
X2.8	"Door blocked" output signal, break contact
X2.9	"Door blocked" output signal, make contact

Table 15: Terminal assignment of the relay outputs (X2)

Connection data

If relays/contactors are switched with the relay outputs, they must be equipped with a freewheeling diode for direct voltage and with an RC combination for alternating voltage.

Version	9-pin connector with push-in spring connection	
Rigid/flexible conductor cross-section (min./max.)	0.2 mm ² /2.5 mm ²	
Stripped length	10 mm	
Flexible conductor cross-section with wire end ferrule with/without plastic sleeve (min./max.)	0.25 mm ² /2.5 mm ²	
AWG conductor cross-section (min./max.)	24/12	
2 conductors with the same cross-section, flexible with TWIN-AEH with plastic sleeve (min./max.)	0.5 mm ² /1.5 mm ²	
AWG according to UL/CUL (min./max.)	26/12	
Power data (UL/CSA)		
Make contact (NO)	1 A/50 VAC	
	1 A/24 VDC	
Break contact (NC)	1 A/50 VAC	
	1 A/24 VDC	
Power data (VDE)		
Make contact (NO)	1 A/230 VAC	
	1 A/230 VDC	
Break contact (NC)	1 A/230 VAC	
	1 A/230 VDC	

Table 16: Connection data of the relay outputs (X2)

Use copper cables only for the connection. For UL-compliant operation, design the cable insulation for a maximum temperature of 60 °C.

ATTENTION

Possible damage

Voltages of different systems must not be connected to the relay outputs (e.g., 24 V and 80 V at the same time).

3.6.5.3 Connection for the stop function (X5)

The TSG V4 electronics are equipped with a stop function (see ▶ [Stop function \[p. 61\]](#)). In normal operation and without use of the stop function there is a jumper wire between terminals X5.1 and X5.2.

CAUTION



Risk of injury and possible damage from unintentional door movements

External voltage at terminals X5.1 or X5.2 can cause unintentional door movements or irreparable damage to the TSG V4 electronics.

— Do not connect any external voltages to terminals X5.1 or X5.2.

Pin	Assignment	
X5.1	Potential-free contact	0 VDC...24 VDC
X5.2	Potential-free contact	

Table 17: Terminal assignment of the connection for the stop function (X5)

Version	2-pin printed board terminal
Rigid/flexible conductor cross-section (min./max.)	0.5 mm ² /1.5 mm ²
Stripped length	5 mm
Flexible conductor cross-section with wire end ferrule with/without plastic sleeve (min./max.)	0.5 mm ² /1.5 mm ²
AWG conductor cross-section (min./max.)	20/15

Table 18: Connection data of the connection for the stop function (X5)

Use copper cables only for the connection. For UL-compliant operation, design the cable insulation for a maximum temperature of 60 °C.

3.6.6 Motor connection

3.6.6.1 Encoder connection (X3)

Version: 9-pin D-sub

Pin	Assignment			
1...4	Not connected			
5	Motor ID			
		Cable core (motor version K)	Cable core (motor version K)	Motor terminal
6	GND	Yellow	Brown	1
7	Channel B	Green	White	5
8	Channel A	Brown	Yellow	3
9	+5 VDC	White	Green	4

Table 19: Terminal assignment of the encoder (X3) with fixed cable on the motor

Pin	Assignment	Pin at the encoder connector
1...4	Not connected	
5	Motor ID	6
6	GND	4
7	Channel B	10
8	Channel A	2
9	+5 VDC	9

Table 20: Terminal assignment of the encoder (X3) with plug-in cable set

ATTENTION

Possible damage

Before plugging in or unplugging the encoder connector, switch off the power supply.

3.6.6.2 Motor connection (X4)

Version: 2-pin screw/plug-in

Pin	Assignment	Core color
1	Motor +	Brown
2	Motor –	White
X8	Motor shield via cable lug 4.8 × 0.8	Housing

Table 21: Terminal assignment of the motor connection (X4)

ATTENTION

Possible damage

- Before plugging in or unplugging the motor connection connector, switch off the power supply.
- Do not change the assignment of the motor connection. Incorrect assignment is detected by the TSG V4 electronics and leads to an interruption in operation and an error message.

3.6.7 External control voltage supply

The control voltage supplied by the internal transformer can be replaced by an insulated connection on site. This external control voltage supply then supplies the logic of the TSG V4 electronics and the encoder of the drive. The load section of the TSG V4 electronics continues to be supplied by the power supply connection. If an external control voltage supply is connected, the two cores of the internal power supply must then be removed from terminals X26 and X27 and properly insulated by the customer against short-circuit.

Pin	Assignment	
X26 ▶ <i>power supply connection of the TSG internal electronics [p. 23]</i>	+	21.6 VDC...27.6 VDC or 16.2 VAC...20.0 VAC 3.9 A max. The maximum fusing of the control circuit must not exceed 4 A.
X27 ▶ <i>power supply connection of the TSG internal electronics [p. 23]</i>	–	
GRD	GRD	

Table 22: Terminal assignment of the connection for external control voltage supply

Version	9-pin printed board terminal
Rigid/flexible conductor cross-section (min./max.)	0.5 mm ² /1.5 mm ²
Stripped length	5 mm
Flexible conductor cross-section with wire end ferrule with/without plastic sleeve (min./max.)	0.5 mm ² /1.5 mm ²
AWG conductor cross-section (min./max.)	20/15

Table 23: Connection data of the connection for external control voltage supply

Use copper cables only for the connection. For UL-compliant operation, design the cable insulation for a maximum temperature of 60 °C.

3.7 TSG options

On request, the TSG V4 is available with various extension options.

3.7.1 TSG web interface

With the optionally available additional TSG web interface electronics and the TVis-Web software, the TSG V4 can be connected to a PC, notebook or tablet. The connection between a PC, notebook or tablet and the TSG web interface can, depending on the scope of supply, either be hard-wired or connected wirelessly via WLAN (WiFi).

TVis-Web is software for visualization of the TSG V4, which can be started directly without installation with a browser (e.g., Microsoft Edge or Mozilla Firefox).

The system supports the following functions:

- Monitoring TSG V4 (remote control, travel profile display, error memory, ...)
- Settings (parameter changes, additional settings, ...)
- System settings (IP address, door values, export/import of the parameters, ...)

For further information see *TVis-Web documentation (1.20.91500)*.

3.7.2 Emergency power supply

The TSG V4 electronics are available with an optional emergency power supply. The emergency power supply consists of a unit additionally attached to the TSG V4 electronics and two NiMh rechargeable batteries.

With the emergency power supply, the door can be opened and closed in case of a power failure. The number of journeys and the speed depend on the weight and ease of movement of the traversing door. A reduced speed is generally to be expected. If the utility power voltage at the TSG V4 electronics has been restored, it switches to normal mode.

If the two batteries are connected correctly, detected by the TSG V4 electronics and are ok, the dot of the right-hand 7-segment display flashes every second when a utility power voltage is applied while the batteries are being charged. If both batteries are completely charged, the TSG V4 electronics switch to trickling charge mode and the dot is lit continuously.

If the batteries are connected and there is no utility power voltage, the dot in the right-hand 7-segment display flashes every 0.5 seconds. If the batteries are exhausted, the TSG V4 and the display are completely switched off (see also ▶ [7-segment display \[p. 40\]](#)).

If the utility power voltage and connected batteries fail, no voltage is applied to terminal X1.6.

3.7.3 Light curtain

To monitor the door area, the TSG V4 can be equipped with a light curtain (TSG light kit). The light curtain consists of a transmitter and receiver bar and monitors the door entrance area. To simplify the mounting, the TSG light kit is equipped with plug-in cables. The mounting time for connecting the electrical part is thus shortened significantly.

The signals arriving from the light curtain can either be evaluated by the elevator controller or directly by the TSG V4.

If the TSG V4 is controlled directly by the light curtain, input X1.3 is used for signal processing. To this end, the parameter **h3** must be configured accordingly (see also ▶ [User setting of the h parameter \[p. 51\]](#)). The signal of the light curtain can be optionally evaluated as "low active" or as "high active". If a signal for opening the door from the light curtain is applied to the TSG V4, the door is opened as long as the light curtain is interrupted.

After a utility power failure and return, the door remains open if the light curtain sends an open signal and the door is not yet referenced.

A control signal at input X1.3 is disregarded by the TSG V4 if the door is within the area of parameter **bb** (capture range for "closed" position, see also ▶ [Using setting of the b parameters \[p. 49\]](#)). The light curtain may not be connected to input X1.3.

For further information see *TSG Light Kit documentation*.

4 Transport and storage

ATTENTION

Possible damage

Improper transportation and improper storage can damage the TSG V4.

- Only transport and store the device in the original packaging.
- Do not remove the required components from the packaging until just before they are mounted.

4.1 Transport

Check the delivery for completeness and intactness. If you find transport damage or that the delivery is not complete, notify your vendor.

4.2 Packaging

Environmentally friendly materials only are used for the packaging. Packaging materials are valuable raw materials and can be reused and recycled. Therefore, add the packaging materials to the recycling cycle. Where this is not possible, dispose of the packaging materials according to the local regulations.

4.3 Storage

Store the TSG V4

- in the original packaging
- not outdoors
- dry, frost and dust-free
- protected against aggressive media and direct sunshine

5 Mechanical mounting

5.1 Requirements

- The door must have fixed mechanical end stops for the “open” and “closed” positions, which withstand the applied energy of the TSG V4
- The end stops must be in the immediate vicinity of the synchronous belt.
- Any closing weight present must not jump.
- The doors must be easy moving.
- Do not install any additional springs (tension or compression springs) in the movement path of the door. Springs and/or dampers that were necessary for door drives used to date must be removed when installing the TSG V4.

5.2 Procedure

5.2.1 Assembly

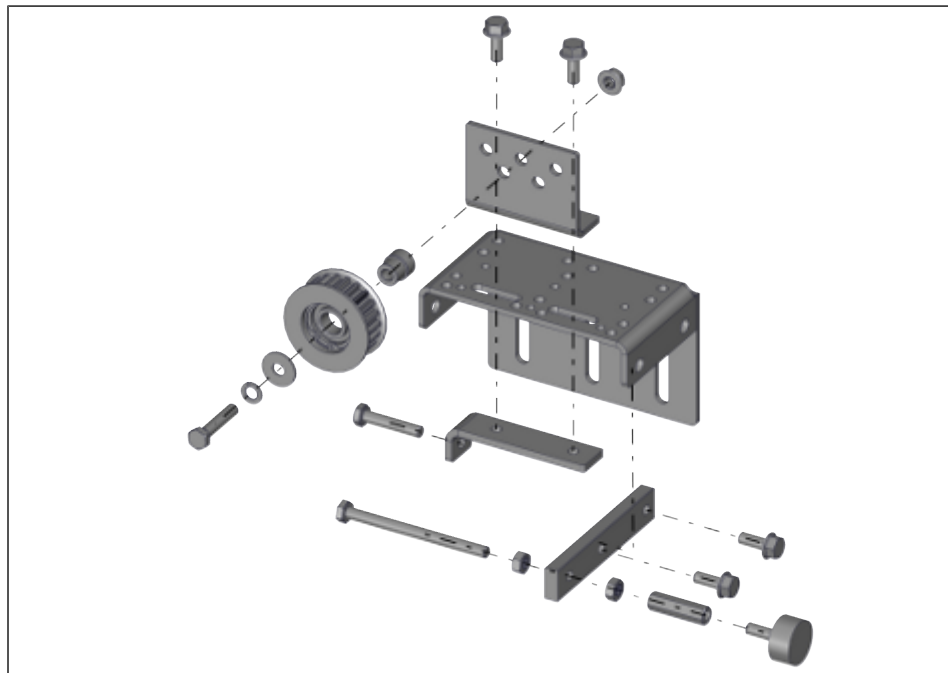

III. 12: Assembly of the deflection unit

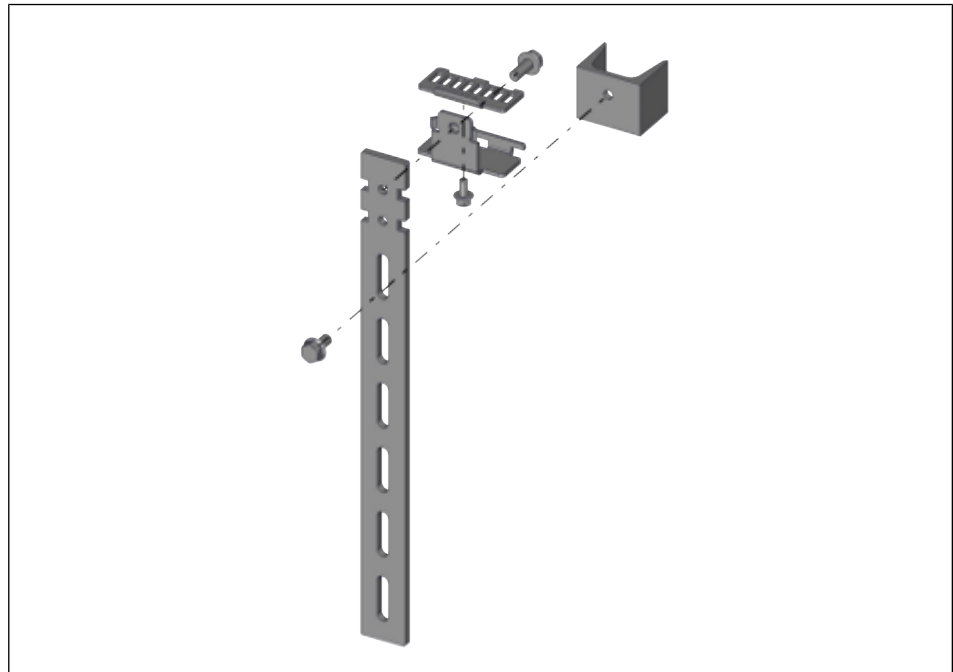

III. 13: Assembly of the adapter unit

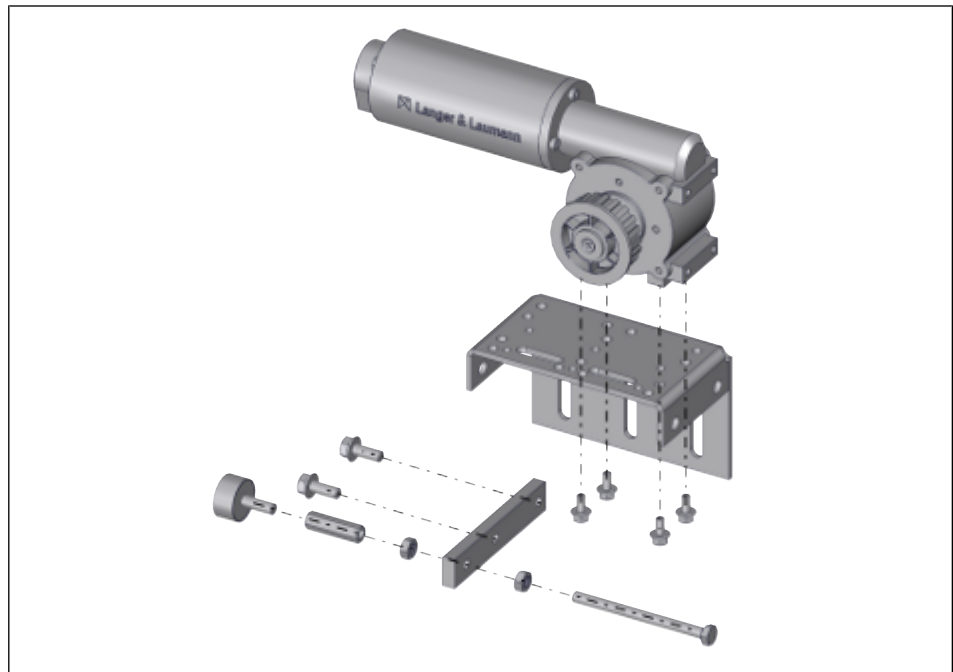

III. 14: Assembly of the drive unit

5.2.2 Mounting on the door

1. Mount the motor of the door drive. It is not important whether the motor is mounted on the open or close side of the door, as the correct travel direction is determined when measuring.
2. Mount the deflection roller and the tensioning station.
3. **ATTENTION**
Only use the TSG synchronous belt locks as synchronous belt lock (door mounting). Unsuitable mountings can exert a notch effect on the synchronous belt, which leads to premature tearing of the synchronous belt.
 Fit the synchronous belt and connect with the synchronous belt lock.
4. Tighten the synchronous belt.
5. Mount the door panel adapter on the fastest door panel and on the synchronous belt lock.
6. If no fixed stops are present, mount buffers on the angled bracket. Screw the C-profile at a suitable height onto the door panel adapter as a mating part.
7. Securely attach the TSG V4 with housing near the drive. Make sure that the motor and encoder cables can be connected with sufficient clearance at the TSG V4 electronics.
8. Connect the 9-pin D-sub connector with socket X3 on the TSG V4 electronics. Plug the motor cable onto terminal block X4 and the shielded terminal of the motor cable on terminal X8 on the TSG V4 electronics.

5.3 Deflection roller

When mounting the deflection roller, make sure that it is fixed with the side of the pressed on flanged washer in the direction of the bracket.

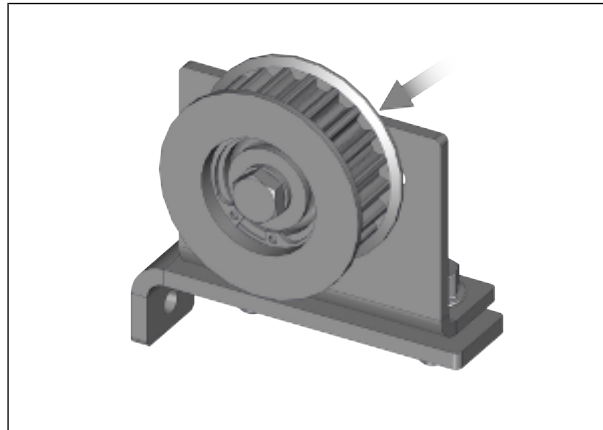

III. 15: Deflection roller mounted

5.4 Synchronous belt

The synchronous belt must be tightened with a specified synchronous belt tension. This ensures optimal force transfer and protection of the synchronous belt and the bearing.

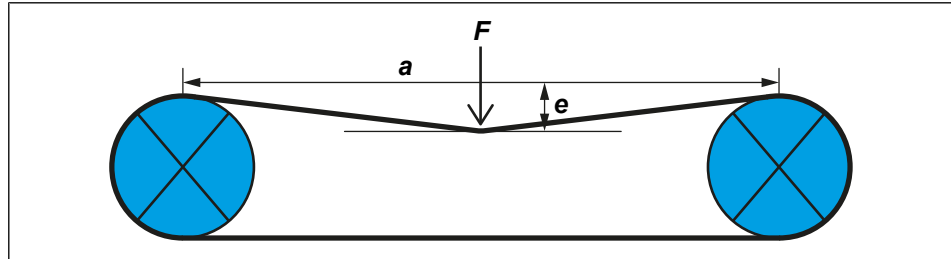

III. 16: Determination of the synchronous belt tension

At a center-to-center spacing a of 1 m (center-to-center of the axes), the deflection e should be 16 mm and the force F 18.5 N.

If the synchronous belt tension is too low it can cause premature wear of the tothing on the synchronous belt. In addition, the synchronous belt can jump on the drive gear or the gear at the deflection roller and therefore cause a changed position of the door. If the synchronous belt is too high, the load on the bearing is increased, the door drive power is reduced and leads to premature wear of the tothing on the synchronous belt.

The synchronous belt pulleys (motor and deflection roller) must be aligned for good alignment. Equally, the shaft parallelism must be checked. The angle deviation must not exceed $\beta = 0.7^\circ$.

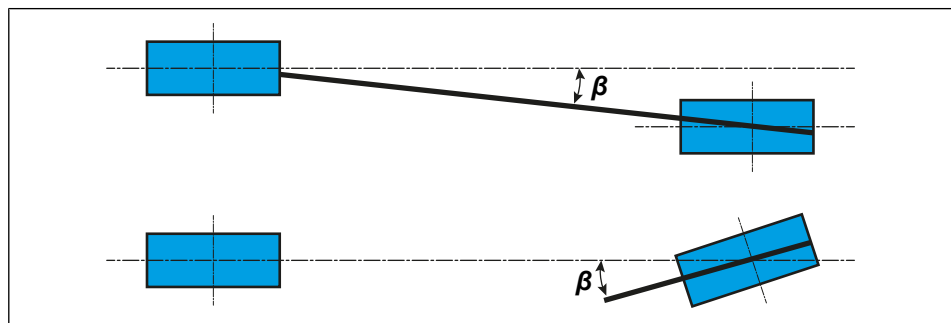

III. 17: Synchronous belt alignment

If the maximum angle deviation is exceeded the synchronous belt can rub against the flanged washers and can cause damage and premature wear to the synchronous belt edge. In addition, the uneven loading of the tension strand which impairs the life considerably.

6 Electric setting, parameterization and commissioning

6.1 Overview

This section describes the diverse setting options of the TSG V4.

The settings of the parameters and the allowable closing forces (kinetic energy, static force) on the main and secondary closing edges must be checked and recorded by the qualified person carrying out the work after the commissioning or after changing parameters (see also ▶ [Door force settings \[p. 58\]](#)).

6.2 7-segment display

On the TSG V4 electronics there is a two-digit 7-segment display to show the applied state and to present the menu with the parameters and their values.











Display	Meaning
	No control is present.
	The TSG is not measured, door learning procedure is required. If the TSG V4 electronics detect an incorrect motor or an incorrect motor connection, the display flashes and a measurement is not possible (see also ▶ Door learning procedure [p. 42]).
	The “open” signal is applied.
	The “close” signal is applied.
	The door is open.
	The door is closed.
	The door is blocked.
	An intermediate position has been reached (see also).
	The reversing distance has been reached (parameter bd , see also ▶ Using setting of the b parameters [p. 49])
	Triggering of the stop function (see also ▶ Stop function [p. 61])
	Triggering of the light curtain (▶ Light curtain [p. 33])

Table 24: Display

The 7-segment display switches off automatically if the jog wheel is not used for 30 minutes. The display is switched on again by turning or pressing the jog wheel.

The two-digit 7-segment display can display up to three-digit values. The front and rear part of the number to be displayed are displayed alternately every second. Two-digit values are displayed without cycling.

Example The parameter **A.C** contains the value 172. The display shows " _ /" for a second and " 72" in the next second.

If the optionally available emergency power supply is installed, then the dot in the right-hand part of the display informs about the operating state.

Emergency power supply status display

Dot in right-hand part	State	Description
Off	TSG V4 Is switched off.	Utility power supply not available and batteries exhausted or not connected.
Flashes (0.5 s intervals)	Battery mode	Utility power supply not available and the batteries supply the TSG V4 electronics.
Flashes (1 s intervals)	Charging mode	Utility power supply available, batteries are being charged.
Lights up	Trickle charging mode	Utility power supply available, batteries are charged, charge is maintained (trickle charging).

Table 25: Emergency power supply status display

6.3 Menu structure

The TSG V4 is operated and set with a jog wheel, which is located on the TSG V4 electronics.

Pressing the jog wheel once from normal mode displays the menu item "P0". Turning the jog wheel clockwise displays the next higher menu item, turning it counterclockwise displays the next lower menu item. Briefly pressing the jog wheel causes a jump to the displayed menu item. If the jog wheel is pressed briefly while "CC" is displayed the display switches to the next higher menu level. Pressing the jog wheel for around five seconds opens setting mode in which the parameter values can be changed by turning the jog wheel. If the required value is displayed, the setting mode is ended by briefly pressing the jog wheel.

If a value is set and saved by pressing the jog wheel, an internal check of successful adoption of the value takes place. If the adoption of the value was not successful, the operator's attention is drawn to this fact by the flashing of the display.

All parameters are saved permanently and are still present after a power failure.

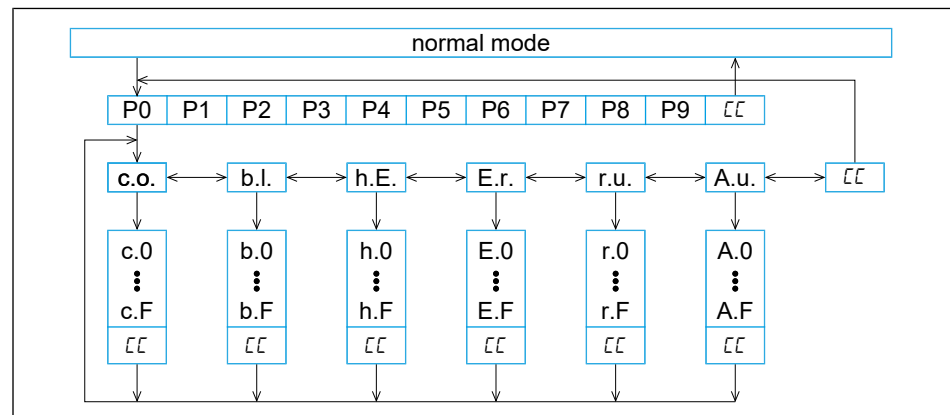

III. 18: Menu structure

6.4 Door learning procedure

CAUTION



Risk of injury

After successful ending of the measuring journey the drive is completely ready.
— During the measuring journey, keep parts of your body away from all moving parts.

After the mechanical mounting, a manual measurement of the TSG V4 must be carried out. At the same time, make sure that the door can close and open unobstructed and thus the determined data are not distorted. The door must not be obstructed by objects or sluggishness.

After each mechanical change (for example, tensioning of the synchronous belt, adjustment of the end stops or buffers), the travel distance can change. Therefore, after each change of the mechanics, a new manual measurement is required.

Preparation for the first commissioning

1. Make sure that the utility power supply is switched off on the input side.
2. Make sure that the connectors X1 (inputs) and X2 (relay outputs) are not plugged into the TSG V4 electronics.
3. Plug the TSG motor cable onto terminal block X4, the shielded terminal of the TSG motor cable onto terminal block X8 and the encoder cable onto terminal block X3.
4. Switch on the utility power supply (input side) at the TSG V4.

Procedure

1. Use your hand to push the door roughly into the middle of the travel distance.
2. Use the jog wheel to select the parameter **P9**. Keep the jog wheel pressed for around five seconds. The preset value of the total weight of the component to be moved (door panels, guard) appears. Turn the jog wheel to set the correct total weight of the component to be moved in increments of 10 kg, note ▶ [Table 26 \[p. 43\]](#). For telescopic doors, only half the weight of the second door panel that is half as much slower is added to the weight. If the correct value is displayed, briefly press the jog wheel to confirm.
 - ⇒ "10" appears in the display.

Display	Total weight [kg]
"01"	10
"02"	20
...	...
"40"	400

Table 26: Weight input

ATTENTION

If the wrong position has been selected for the "Open" direction and the "Open" position has already been saved, then it is no longer possible to reverse the travel direction with the jog wheel. The measuring must be continued to the end and then a new measurement started.

3. Select the "open" direction first by turning the jog wheel in one direction. If the door moves in the "Close" direction instead of the "Open" direction, then turn the jog wheel in the opposite direction to reverse the direction of movement of the drive.
 - ⇒ If the door has reached and saved the "open" position, the door moves to the "closed" position automatically.
 - ⇒ If the "Close" position is reached and the "c0" display is shown, then the measuring is successfully completed and the connectors X1 (inputs) and X2 (relay outputs) can be plugged in.
 - ⇒ If "nL" appears in the display, the measuring was not successful and must be repeated. If an error message is displayed, the fault must be removed first (see ▶ [Troubleshooting \[p. 67\]](#)).

If the parameters are reset to standard with the parameter **EE**, the last set weight is retained. Renewed input of the weight is only possible with subsequent door learning procedure.

6.5 Manual mode/manual travel

1. Use the jog wheel to select the parameter **P1**.
⇒ "Hd" appears in the display.
2. Turn the jog wheel counterclockwise and the "-o" display appears. If the jog wheel is pressed and held, the door then moves in the "Open" direction. Turn the jog wheel clockwise and the "-c" display appears. If the jog wheel is pressed and held, then the door moves in the "Close" position. Let go of the jog wheel to stop the door.
3. To end manual mode, turn the jog wheel until the "Hd" display appears and then press the jog wheel.

Moving in manual mode corresponds to the same travel behavior caused by applying input signals to terminals X1.1 or X1.2.

As long as the TSG V4 is in manual mode, input signals at terminals X1.1 and X1.2 are ignored. If the jostle function is activated (**h3 = 03**), this function can be carried out by applying the input signal at terminal X1.3 and at the same time, manual travel in the "Close" direction. If the TSG V4 is to be moved again via input signals at terminal block X1, manual mode must be ended.

If the stop function is activated in manual mode the manual mode is then ended. If an error occurs in manual mode the manual mode is also ended. It cannot be reactivated until the error has been removed.

As long as the TSG V4 is in manual mode, LED 10, LED 11 and LED 12 continue to indicate the applied input signals (► [Interfaces and displays of the TSG V4 electronic \[p. 19\]](#)); however, the input signals are ignored.

6.6 Default parameters

6.6.1 Basic setting

The TSG V4 is delivered with an executable basic setting, which generally does not have to be changed.

6.6.2 Travel profiles with default parameters

The following diagrams show schematically which parameters affect which sections of the travel profiles.

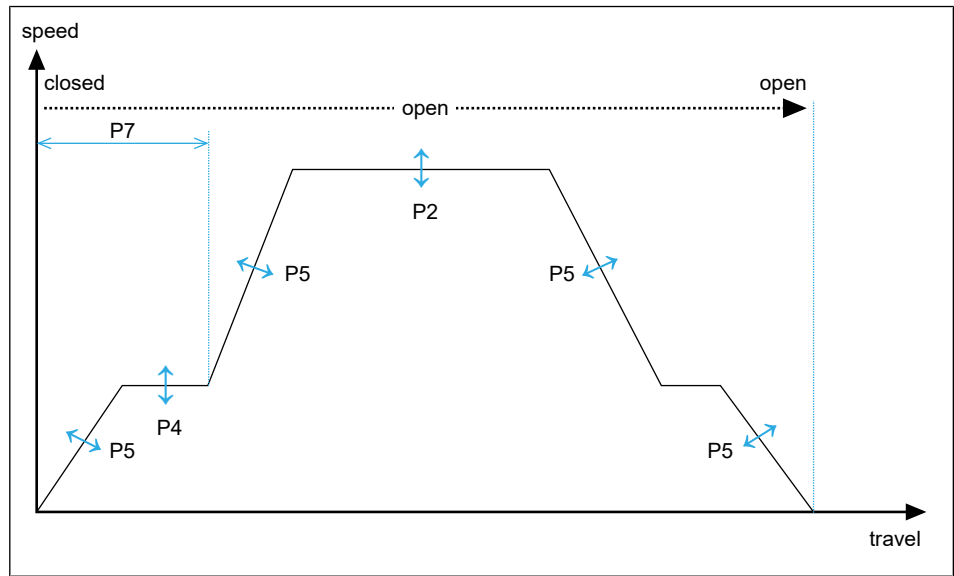

III. 19: "Open" travel profile with default parameters

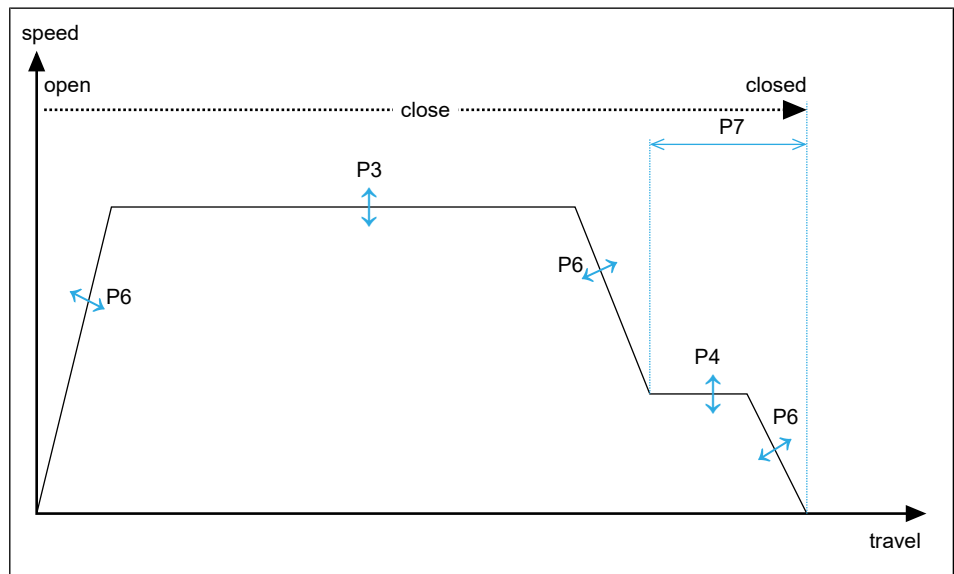

III. 20: "Close" Travel profile with default parameters

6.6.3 User setting of the P parameters

The default parameters (P parameters) enable fast adjustment of the most important properties of the TSG V4 and thus fast setting of the travel values.

Par.	Function	Note	Min.	Standard	Max.	Factor	Unit
P0	Access to the extended menu	See also ▶ Extended parameters [p. 47]					
P1	Manual mode	See also ▶ Manual mode/manual travel [p. 44]					
P2	Maximum opening speed		01	50	99	0.01	m/s
P3	Maximum closing speed		01	30	99	0.01	m/s
P4	Locking and unlocking speed	Creep speed just before the end position (closed)	01	05	P3	0.01	m/s
P5	Acceleration and braking in the opening direction		01	07	50	0.1	m/s ²
P6	Acceleration and braking in the closing direction		01	07	50	0.1	m/s ²
P7	Locking and unlocking distance	Creep distance just before the end position (closed)	00	03	99	1	cm
P8	"Blocked detection" threshold value in closing direction		0.1	4.0	9.9	1	
P9	Set-up activation	See also ▶ Door learning procedure [p. 42]					
CC	Ext the current level of the menu.						

Table 27: P parameters

6.7 Extended parameters

6.7.1 Travel profiles with extended parameters

The following diagrams show schematically which parameters affect which sections of the travel profiles.

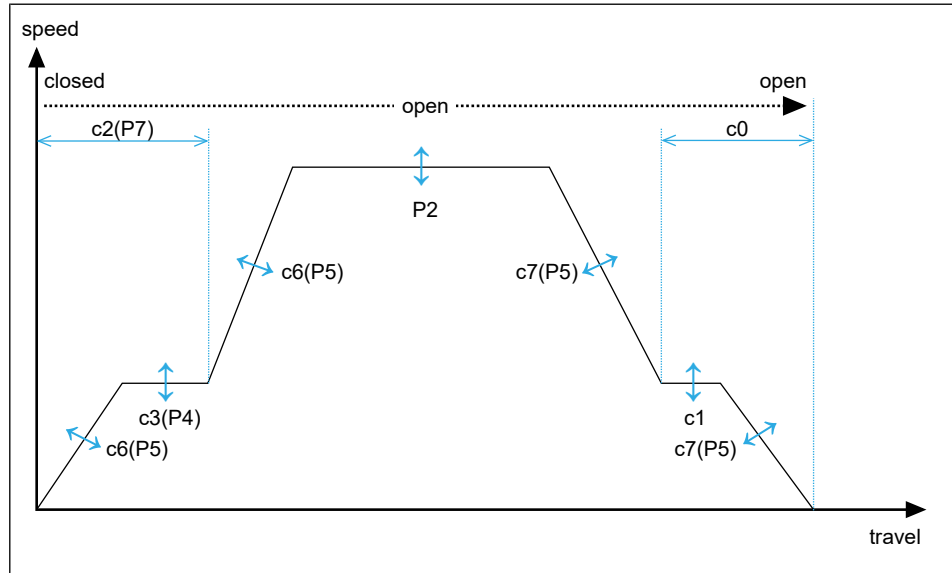

III. 21: "Open" travel profile with extended parameters

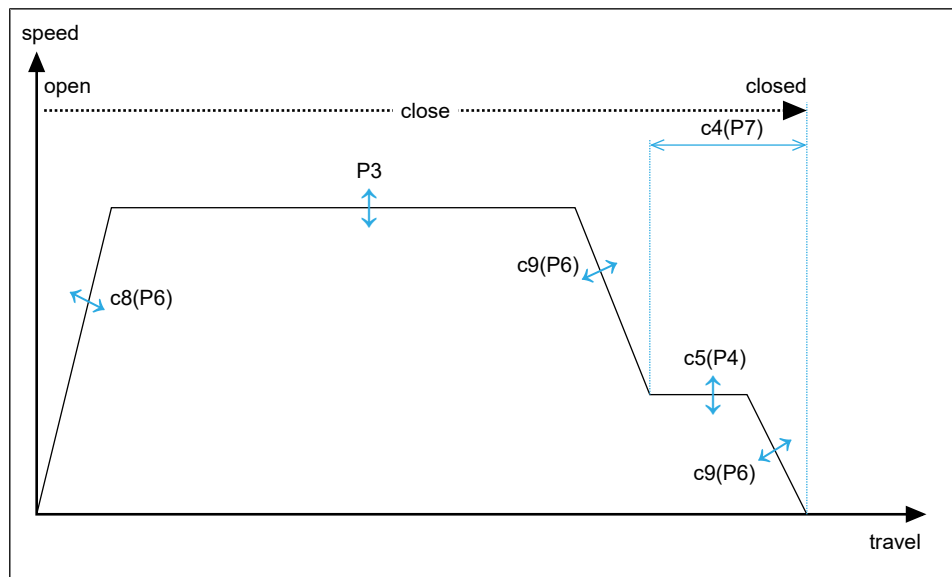

III. 22: "Close" Travel profile with extended parameters

6.7.2 User setting of the c parameters

The travel values can be set using the c parameters to adjust the travel values individually to the respective use case. It must be noted that when some P parameters are changed, several c parameters are also changed at the same time. This means that the value to which a P parameter is set is automatically entered in the corresponding c parameter.

Par.	Function	Note	Min.	Standard	Max.	Factor	Unit
c0	Creep distance length in opening direction		00	02	(internal calculation)		cm
c1	Creep speed in opening direction		01	05	0,25 or P2 : opening speed	0.01	m/s
c2	Length of the unlocking distance in the opening direction		00	03	(internal calculation)		cm
c3	Unlocking speed in the opening direction		01	05	0,25 or P2 : opening speed	0.01	m/s
c4	Length of the locking distance in the closing direction		00	03	(internal calculation)		cm
c5	Locking speed in the closing direction		01	05	0.25 or P3 : maximum closing speed	0.01	m/s
c6	Acceleration in the opening direction		01	03	50	0.1	m/s ²
c7	Deceleration in the opening direction		01	03	50	0.1	m/s ²
c8	Acceleration in the closing direction		01	03	50	0.1	m/s ²
c9	Deceleration in the closing direction		01	03	50	0.1	m/s ²
cC	Holding torque in opening direction without the "Open door" input signal		0.0	1.0	2.5		A
cd	Holding torque in closing direction with "Close door" input signal		0.0	1.0	2.5		A
cE	Holding torque in opening direction with "Open door" input signal		0.0	1.0	2.5		A

Par.	Function	Note	Min.	Standard	Max.	Factor	Unit
cF	Holding torque in closing direction with "Close door" input signal		0.0	1.0	2.5		A
CC	Ext the current level of the menu.						

Table 28: c parameters

6.7.3 Using setting of the b parameters

Par.	Function	Note	Min.	Standard	Max.	Factor	Unit
b2	Threshold value for obstacle detection in the closing direction	Closing force measurement	2.0	4.0	9.9		A
b3	Reaction of the "Door blocked" relay output in the closing direction	oF: continuously on: pulse On activating the threshold value for obstacle detection in the closing direction the "Door blocked" output is set. The "Door blocked" output is reset when the "Open" position is reached.	oF	oF	on		
b4	Reaction of the door drive in case of blocking in the closing direction	oF: if the door is blocked, the drive stops immediately. Opening of the door if the input signal changes to "Open door". on: automatic reversing also with "the "Close door" input signal until the "open" position is reached. If the "Close door" input signal is still applied the door then closes again immediately. The parameter h5 can be used to set the hold-open time (► User setting of the h parameter [p. 51]).	oF	oF	on		
b5	Activation of the blocked detection in the opening direction	oF: off on: on	oF	on	on		
b6	Blocked detection in the first 30 % of the opening distance	oF: blocked detection off in the first 30 % of the opening distance on: blocked detection on in the whole opening distance	oF	on	on		
b7	Threshold value for the blocked detection in the opening direction		2.0	9.5	9.9		A
b8	Reaction of the "Door blocked" relay output in the opening direction	oF: continuously on: pulse	oF	on	on		

Par.	Function	Note	Min.	Standard	Max.	Factor	Unit
b9	Reaction of the door drive in case of blocking in the opening direction	<p>oF: if the door is blocked, the drive stops immediately. Closing of the door when the input signal changes to "Close door".</p> <p>on: automatic reversing even with "Open door" input signal until the "closed" position is reached. If the "Open door" input signal is still applied the door then opens again immediately.</p>	oF	oF	on		
bA	Length of the output pulse at the "Door blocked" relay output in the opening and closing direction	Only effective if b3 and/or b8 = on	0.1	1.0	2.0		s
bb	Capture range for the "door closed" position	The obstacle detection is not active in this area.	01	05	50		mm
bC	Capture range for the "door open" position	The obstacle detection is not active in this area.	01	10	50		mm
bd	Reversing distance	<p>Effective for obstacle detection and sensor monitoring.</p> <p>Obstacle detection If the door is blocked, the TSG V4 reverses by the set value. If the value is set to 00 or 99, complete reversing takes place. Only active if the parameter b4 or b9 has been activated. The smallest reversing distance to be carried out is 5 cm.</p> <p>Sensor monitoring If the sensor is triggered on closing, the TSG V4 reverses by the set value. If the value is set to 99, complete reversing takes place. The smallest reversing distance to be carried out is 5 cm.</p>	00	99	99		cm
bE	Slow movement to blocked position	If the door was blocked in the closing direction, the TSG V4 moves slowly to the blocked position with the next closing movement.	oF	on	on		
CC	Ext the current level of the menu.						

Table 29: b parameters

6.7.4 User setting of the h parameter

Par.	Function	Note	Min.	Standard	Max.	Factor	Unit
h0	Continuous test: Open door/close door/ bus system baud rate setting		00	00	03		
		The door opens and closes continuously. The input signals at X1 are ignored. There is a pause of 5 seconds between the individual travel movements. If hA = 09, 10, 16, 17 or 18: setting of the baud rate in operation with bus system. In "Control by means of bus system" mode the parameter h0 has a different meaning, see accompanying manual for the respective TSG option.					
h1	Inputs and outputs setting/ door number bus system setting		00	00	03		
		00: has no function 01: test operation of the inputs and outputs — Input X1.1 switches relay output X2.2 or X2.3 — Input X1.2 switches relay output X2.5 or X2.6 — Input X1.3 switches relay output X2.8 or X2.9 02: pulsed mode of inputs X1.1 and X1.2 (pulse length at least 0.2 s). 03: pulsed mode of input X1.1 (pulse length at least 0.2 s). Input X1.2 is not evaluated. When the pulse is applied the door opens completely and closes automatically after the time set with h5 has expired. If hA = 09, 10, 16, 17 or 18: setting of the door number in operation with bus system. In "Control by means of bus system" mode the parameter h1 has a different meaning, see accompanying manual for the respective TSG option.					
h2	Leading limit switch		00	00	31		
		The relay outputs for "Door open" or "Door closed" (terminal block X2) can be set to be leading. In keeping with the configuration, they switch before the reached-in end position has been completely reached (see ▶ Leading limit switch [p. 62]).					
h3	Input X1.3 function		00	00	05		
		00: stop function (see ▶ Stop function [p. 61]) 01: light curtain "high active" (if LED 12 lights up the door opens) 02: light curtain "low active" (if LED 12 goes out the door opens) 03: closing of the door if protective device is deactivated or failed (see ▶ Closing the door on deactivation or breakdown of the external protective device [p. 60]). 04: reserved 05: stop function, the door stops if the input signal is interrupted. 06: has no function 07: TSG connection set, light grid mode The parameter h3 is not reset to default on loading the default settings (see also ▶ Error with displayed error code [p. 68]). If the parameter h3 is set to 01, 02 or 07, the reversing distance can be set via the parameter bd and the reversing time via parameter h5 .					
h4	In "Control by means of bus system" mode the parameter h4 has a different meaning, see accompanying manual for the respective TSG option.						
h5	Reversing time		00	00	99		s
		If the "Automatic reversing" function is active (b4 = 01) or "Pulsed operation X1.1" (h1 = 03), the door remains active for the set value. If the value is 00, the door closes again immediately. If the door is opened, the time is counted back and the remaining value is shown in the display.					

Par.	Function	Note	Min.	Standard	Max.	Factor	Unit
h6	Speed after return of utility power supply and speed while measuring.	Speed on referencing the two end positions after voltage return and during the measuring (see also ▶ User setting of the P parameters [p. 46] , P9).	01	15	25	0.01	m/s
h7	TSG sine drive opening time	Only if the optional additional TSG sine drive circuit board is used, see parameter setting hA in the accompanying documentation.	00	50	80		1/100 s
h8	Force for checking end position in CLOSED		0.1	3.5	9.9		A
h9	Force for checking end position in OPEN		0.1	1.0	9.9		A
hA	Mode selection (see ▶ Mode setting with parameter hA [p. 53])	Only if the corresponding optional additional circuit board is used.	00	00	99		
hb	TSG sine drive closing time	Only if the optional additional TSG sine drive circuit board is used, see parameter setting hA in the accompanying documentation.	01	50	80		1/100 s
hC	Pause between opening the TSG sine drive and the opening of the door	Only if the optional additional TSG sine drive circuit board is used, see parameter setting hA in the accompanying documentation.	01	50	499		1/100 s
hd	Force for checking the end position when measuring in CLOSED	If the parameter is reduced, renewed measuring must then take place.	0.1	3.0	9.9		A
hE	Force for checking the end position when measuring and referencing in OPEN	If the parameter is reduced, renewed measuring must then take place.	0.1	3.0	9.9		A
hF	Suppression of blocked detection in the last (maximum) 50 mm of the closing travel.	The maximum 50 mm is made up of the values of the parameters bb and hF . Example: bb = 10 mm => bb = maximum 40 mm. In The blocked detection is not active in this area.					
CC	Ext the current level of the menu.						

Table 30: h parameter

6.7.5 Mode setting with parameter hA

Value hA	Function	Accompanying documents
00	Operation of the TSG V4 without extension	
01	TSG sine drive control	<i>1.20.94090_xx_Instructions_Vx.x_TSG sine drive</i>
02	reserved	
03	TSG sine drive control with emergency power supply	<i>1.20.94090_Instructions_Vx.x_TSG sine drive</i>
04	reserved	
05	reserved	
06	TSG sine drive control for swing landing door	<i>1.20.94090_Instructions_Vx.x_TSG sine drive</i>
07	TSG V4 with Otis 3-wire communication interface	<i>1.20.91805_xx_Instructions_Vx.x_TSG_in_DCSS5_AT120</i>
08	reserved	
09	reserved	
10	TSG V4 with CanOpen bus communication interface TSG V4 with ThyssenFx bus communication interface	<i>1.20.91555_xx_Instructions_Vx.x_TSG-V4-CanOpen</i> <i>1.20.92620_xx_Instructions_Vx.x_TSG-V4-Thyssen-CAN</i>
11	reserved	
12	reserved	
13	TSG V4 with Otis Multidrop communication interface	<i>1.20.91806_xx_Instructions_Vx.x_TSG_in_OTIS_Multidrop</i>
14	reserved	
15	reserved	
16	TSG V4 with CanOpen bus communication interface and TSG sine drive control TSG V4 with ThyssenFx bus communication interface and TSG sine drive control	<i>1.20.91555_xx_Instructions_Vx.x_TSG-V4-CanOpen</i> <i>1.20.92620_xx_Instructions_Vx.x_TSG-V4-Thyssen-CAN</i> <i>1.20.94090_xx_Instructions_Vx.x_TSG sine drive</i>
17	TSG V4 with CanOpen bus communication interface, TSG sine drive control and emergency power supply TSG V4 with ThyssenFx bus communication interface, TSG sine drive control and emergency power supply	<i>1.20.91555_xx_Instructions_Vx.x_TSG-V4-CanOpen</i> <i>1.20.92620_xx_Instructions_Vx.x_TSG-V4-Thyssen-CAN</i> <i>1.20.94090_xx_Instructions_Vx.x_TSG sine drive</i>
18	TSG V4 with CanOpen bus communication interface, TSG sine drive control for swing landing door TSG V4 with ThyssenFx bus communication interface, TSG sine drive control for swing landing door	<i>1.20.91555_xx_Instructions_Vx.x_TSG-V4-CanOpen</i> <i>1.20.92620_xx_Instructions_Vx.x_TSG-V4-Thyssen-CAN</i> <i>1.20.94090_xx_Instructions_Vx.x_TSG sine drive</i>
19	TSG V4 with control of the cabin door lock (FKTV)	<i>1.20.92630_xx_Instructions_Vx.x_TSG-FKTV</i>
20	TSG V4 with control of the cabin door lock (FKTV) and TSG sine drive	<i>1.20.92630_xx_Instructions_Vx.x_TSG-FKTV</i> <i>1.20.94090_xx_Instructions_Vx.x_TSG sine drive</i>
21	TSG V4 with control of the cabin door lock (FKTV) and TSG sine drive for swing landing door	<i>1.20.92630_xx_Instructions_Vx.x_TSG-FKTV</i> <i>1.20.94090_xx_Instructions_Vx.x_TSG sine drive</i>
22	TSG V4 with CanOpen bus communication interface and control of the cabin door lock (FKTV) TSG V4 with ThyssenFx bus communication interface and control of the cabin door lock (FKTV)	<i>1.20.91555_xx_Instructions_Vx.x_TSG-V4-CanOpen</i> <i>1.20.92620_xx_Instructions_Vx.x_TSG-V4-Thyssen-CAN</i> <i>1.20.92630_xx_Instructions_Vx.x_TSG-FKTV</i>

Value hA	Function	Accompanying documents
23	TSG V4 with CanOpen bus communication interface and control of the cabin door lock (FKTV) and TSG sine drive TSG V4 with ThyssenFx-Bus communication interface and control of the cabin door lock (FKTV) and TSG sine drive	1.20.91555_xx_Instructions_Vx.x_TSG-V4-CanOpen 1.20.92620_xx_Instructions_Vx.x_TSG-V4-Thyssen-CAN 1.20.92630_xx_Instructions_Vx.x_TSG-FKTV 1.20.94090_xx_Instructions_Vx.x_TSG sine drive
24	TSG V4 with CanOpen-Bus communication interface and control of the cabin door lock (FKTV) and TSG sine drive for swing landing door TSG V4 with ThyssenFx-Bus communication interface and control of the cabin door lock (FKTV) and TSG sine drive for swing landing door	1.20.91555_xx_Instructions_Vx.x_TSG-V4-CanOpen 1.20.92620_xx_Instructions_Vx.x_TSG-V4-Thyssen-CAN 1.20.92630_xx_Instructions_Vx.x_TSG-FKTV 1.20.94090_xx_Instructions_Vx.x_TSG sine drive
25	reserved	
26	reserved	
27	TSG V4 with non-contact synchronization of power-driven landing doors - cabin door	1.20.92670_xx_Instructions_V1.4_TSG Non-Contact synchronization
28	TSG V4 with non-contact synchronization of power-driven landing doors - landing door	1.20.92670_xx_Instructions_V1.4_TSG Non-Contact synchronization
29	TSG V4 with Otis 3-wire communication interface with control of the cabin door lock (FKTV) TSG V4 with Otis 3-wire communication interface with control of the cabin door lock (FKTV) and TSG sine drive TSG V4 with Otis Multidrop communication interface with control of the cabin door lock (FKTV) TSG V4 with Otis Multidrop communication interface with control of the cabin door lock (FKTV) and TSG sine drive	1.20.91805_xx_Instructions_Vx.x_TSG_in_DCSS5_AT120 1.20.91806_xx_Instructions_Vx.x_TSG_in_OTIS_Multidrop 1.20.92630_xx_Instructions_Vx.x_TSG-FKTV 1.20.94090_xx_Instructions_Vx.x_TSG sine drive
30	reserved	
31	reserved	
32	TSG V4 with customized setting	1.20.91866

Table 31: Mode setting with parameter hA

6.7.6 Error codes (E parameters)

Par.	Function	Min.	Standard	Max.	Unit	Ready	Reset
E0	Travel not limited	00	00	999	Quantity	No	Automatically after 15 s or Power on reset
E1	Travel disabled	00	00	999	Quantity	No	Automatically after 15 s or Power on reset
E2	EEPROM error	00	00	999	Quantity	No	Power on reset
E3	Blocked on reversing	00	00	999	Quantity	No	Automatically after 15 s or Power on reset
E4	Encoder signals not clear or not available	00	00	999	Quantity	No	Automatically after 15 s. Shutdown of the drive after several attempts without change. Power on reset.
E5	Current sensor monitoring triggered	00	00	999	Quantity	No	Automatically after 15 s. Shutdown of the drive after several attempts without change. Power on reset.
E6	TSG internal monitoring	00	00	999	Quantity	No	Automatically after 15 s. Shutdown of the drive after several attempts without change. Power on reset.
E7	Blocked after switching back on	00	00	999	Quantity	No	Automatically after 15 s or Power on reset
E8	Number of restarts	00	00	999	Quantity	Yes	–
E9	Monitoring of stop input, end stage, self-diagnosis	00	00	999	Quantity	No	Automatically after 15 s. Shutdown of the drive after several attempts without change. Power on reset.
EA	Overcurrent in standstill	00	00	999	Quantity	No	Automatically after 15 s or Power on reset
Eb	Voltage error	00	00	999	Quantity	No	Automatically after 15 s or Power on reset
EC	Motor not ok	00	00	999	Quantity	No	Automatically after 15 s. Shutdown of the drive after several attempts without change. Power on reset.
Ed	Motor detection is faulty	00	00	999	Quantity	No	Restart directly possible if the motor is detected
EE	Load default settings	0F	0F	0n	0F: off 0n: on	–	–
EF	Delete error counter	0F	0F	0n	0F: off 0n: on	–	–
CC	Ext the current level of the menu.						

Table 32: E parameters

6.7.7 Operating state (r parameters)

Par.	Function	Unit	Note
r0	Actual speed	m/s	Displays the momentary speed.
r1	Setpoint speed	m/s	Displays the specified speed.
r2	Current motor current	A	Displays the current motor current.
r3	End stage operating voltage	VDC	Displays the current voltage in the end stage.
r4	Utility power supply	VAC	Displays the last two digits of the utility power voltage. Example: Display 30: utility power voltage = 230 VAC.
r5	Temperature	°C	Displays the current temperature in the end stage.
r6	Door width (xx0000)	10 m	Displays the measured door width in multiples of ten meters.
r7	Door width (00xx00)	dm	Displays the measured door width in decimeters.
r8	Door width (0000xx)	mm	Displays the measured door width in millimeters.
r9	Current door status (xx0000)	10 m	Displays the current door status in multiples of ten meters.
rA	Current door status (00xx00)	dm	Displays the current door status in decimeters.
rb	Current door status (0000xx)	mm	Displays the current door status in millimeters.
rC	Operating hours (xx0000)	h	Displays the operating hours achieved.
rd	Operating hours (00xx00)	h	Displays the operating hours achieved.
rE	Operating hours (0000xx)	h	Displays the operating hours achieved.
rF	Friction	A	
CC	Exit the current menu level		

Table 33: r parameters

6.7.8 User setting of the Au parameters

Par.	Function	Note	Min.	Standard	Max.	Factor	Unit
A0	Setting of the door unlocked position	See <i>Application note 1.20.91520 "Door unlocking via the skate"</i> . If the door arrives in the closed and locked position and the close door signal then drops away, the setting in parameter A0 drops off. The door moves by the distance set in A0 and takes up the closed and locked position. 00: door stays stopped in the closed and locked position 01...04: the door opens by 5 mm 05...999: the door opens by the set value in mm	00	00	999		mm
A1	Reversing brake value	Active if the "Close door" input signal is removed or is reversed.	01	15	50	0.1	m/s ²
A2	Setting of the buffer time between reaching the door zone and unlocking of the door. Only valid in operation with a door lock controlled by the TSG V4.	Setting in 100 ms increments (see <i>manual 1.20.92630 "TSG TKTV documentation"</i>).	0	80	99	0.1	s
A3	Distance of the door opening. Only valid in operation with a door lock controlled by the TSG V4.	See <i>Manual 1.20.92630 "TSG TKTV documentation"</i> .	0	5	99	1 Divisor: 1	cm
A4	Behavior of the "closed" limit switch on carrying out the function of parameter A0 . Only relevant if the "Setting of the door unlocked position" function is active (see parameter A0). Only valid in operation with a door lock controlled by the TSG V4.	See <i>Application note 1.20.91520 "Door unlocking via the skate"</i> . 00 and all other settings > 02: The "closed" limit switch drops off when the door leaves the closed position. 01: the "closed" limit switch is active while the function after A0 is being carried out, however, drops off when the door and door unlocked position are located 100 mm away from the door locked position. 02: The "closed" limit switch is active while the function after A0 is being carried out, as long as the door is within the distance of parameter A0 .	0	0	99		
A8	Additional mechanical transmission	See ► Mechanical transmission [p. 63] .	05	1.0	8.0		
A9	Release of the parameter A8	See ► Mechanical transmission [p. 63] .	00	00	01		
AA	User-defined parameter sets.	Change only after consulting the support of Langer & Laumann.	00	00	99		

Par.	Function	Note	Min.	Standard	Max.	Factor	Unit
Ab	Reset IP address in TVis web interface to 172.16.1.150.		X	X	X	X	X
AC	IP0		X	X	X	X	X
Ad	IP1		X	X	X	X	X
AE	IP2		X	X	X	X	X
AF	IP3		X	X	X	X	X
CC	Ext the current level of the menu.						

Table 34: Au parameters

6.8 Door force settings

6.8.1 Basic principles

The maximum allowable speeds, forces and energy values must be checked and recorded by the qualified person carrying out the work at the closing and shear edges after commissioning or after changing parameters at the door. A closing force measuring device for determining dynamic and static forces can be borrowed from Langer & Laumann.

6.8.2 Maximum kinetic energy

According to the relevant standards, the maximum kinetic energy W_{kin} at the closing and shear edges must not exceed 10 J. To this end, it is necessary to know the actual total weight of the component to be moved (door panels, guard, ...) and to enter them before the measuring (see also ▶ [Door learning procedure \[p. 42\]](#)).

On exceeding the specified value for the kinetic energy, the speed must be lowered so that the limits can be met. The maximum speed to be set is calculated as follows:

$$v = \sqrt{\frac{2 \cdot W_{kin}}{m}} \quad \rightarrow \quad v [m/s] = \sqrt{\frac{2 \cdot 10 \text{ J}}{m [kg]}}$$

Where

- v : maximum allowed speed [m/s]
- W_{kin} : kinetic energy [J]
- m : weight [kg]

6.8.3 Maximum static force

According to the relevant standards, the maximum static force F at the closing and shear edges must not exceed 150 N. The parameter **P8** (or **b2** closing direction, **b7** opening direction) sets the values for the maximum static force. By increasing the value in **P8** (or **b2** closing direction, **b7** opening direction), the threshold value for obstacle detection is increased.

6.8.4 Obstacle detection in closing direction

If the door is blocked in the closing direction and the obstacle detection is activated, the door remains stopped as long as the “Close door” input signal is still applied. At the same time, the relay for “Door blocked” switches. If the “Close door” input signal is still applied, the door continues moving in the closing direction after 5 s.

If it is rerouted (the “open door” input signal is applied), the door moves open in a controlled way. The relay for “door blocked” is switched off as soon as the “open” position is reached. The position at which the door was blocked is saved in the TSG V4 for the next journey. If the “Close door” input signal is applied again, the door travels with normal speed up to approx. 5 cm in front of the obstacle and continues traveling with slow speed (parameter to be set **h6**). If the obstacle is removed, the door continues moving to approx. 5 cm after the obstacle with normal speed. The function of the speed change at the blocked position must be switched off or on by the parameter **bE**.

If the parameter **b4** = **on**, the door is reversed automatically in case of blocking. After reaching the “open” position the door closes again. The reversing distance can be set using the parameter **bd**. If **bd** is larger than 00, the door reverses by at least 5 cm. If **bd** = 00, complete reversing takes place.

If the parameter **b3** = **on**, the blocked relay is controlled with only one pulse. The length of the pulse is set with parameter **bA**.

The threshold value for the height of the obstacle detection in the closing direction can be set with the parameter **P8** or **b2** and must be checked at the installed door machine.

6.8.5 Obstacle detection in opening direction

If the door is blocked in the opening direction and the obstacle detection is activated, the door remains stopped as long as the “Open door” input signal is still applied. At the same time, the relay for “Door blocked” switches. If the “Open door” input signal is still applied, the door continues moving in the opening direction after 5 s. If it is rerouted (the “Close door” input signal is applied), the door moves in a controlled way, the relay for “Door blocked” is switched off as soon as the “closed” position is reached. If a “Open door” input signal is given again, the door continues moving with normal speed.

The obstacle detection in the opening direction is switched on by default and can be switched off with the parameter **b5** = **oF**. If the obstacle detection is switched on in the opening direction it is active in the whole travel.

In the first 30 % of the travel of the opening direction the obstacle detection can be switched off by the parameter **b6** = **oF**.

If the parameter **b9** = **on**, the door is reversed automatically in case of blocking. After reaching the “closed” position the door opens again. The reversing distance can be set using the parameter **bd**. If **bd** is larger than 00, the door reverses by at least 5 cm. If **bd** = 00, complete reversing takes place.

If the parameter **b8** = **on**, the blocked relay is controlled with only one pulse. The length of the pulse is set with parameter **bA**.

The threshold value for the height of the 150 N detection in the opening direction can be set with the parameter **b7**.

6.9 Special functions

6.9.1 Holding torque in the end positions

A holding torque can be set in the end positions. The holding door causes the door to be held in the respective end position with a force to be set. A differentiation is made between whether an input signal is applied at the inputs ("Open door" or "Close door") or not.

If the holding torque acts in the end position, a value of approx. 35 N/A can be assumed as a guide value for the static force (parameter setting **cC**, **cd**, **cE**, **cF**) (requirements: no external force action, no mechanical transmission, TSG drive with 24 V nominal voltage).

ATTENTION

A holding torque that is too high reduces the life of the motor.

— Only set the holding torque as high as absolutely required.

6.9.1.1 Holding torque without applied input signal

A holding torque can be set so that the door is held in the end position even if an input signal is not applied at the TSG V4. The holding torque in the "open" position without "Open door" signal is set with the parameter **cC**, the holding torque in the "closed" position without "Close door" signal with the parameter **cd**.

Example The higher-level control system issues the "Close door" input signal, the door moves closed. If the door is closed, the input signal is removed by the control system and the door is de-energized. On traveling the shaft, it is now possible for the door to slowly stop due to vibrations or mechanical stress in the system and the safety circuit is opened. The holding torque can be variably set to prevent this.

6.9.1.2 Holding torque with applied input signal

A holding torque can be set so that the door is held in the end position even if an input signal is applied at the TSG V4. The holding torque in the "open" position without "Open door" signal is set with the parameter **cE**, the holding torque in the "closed" position with "Close door" signal with the parameter **cd**.

6.9.2 Closing the door on deactivation or breakdown of the external protective device

If an external protective device (e.g., light grid) is deactivated or fails on closing the door, the maximum kinetic energy W_{kin} at the closing and shear edges must be reduced and must not exceed 4 J.

The jostle function can be used if an external protective device is deactivated or fails on closing the door.

If the parameter **h3** = 03 is set, the jostle function can be executed by simultaneously applying the input signals X1.2 and X1.3. If the "Close signal and the "Jostle" signal are applied at the same time, the door moves with slower speed. On reaching the obstacle the force is switched to a fixed value after a second.

6.9.3 Stop function

The following figure shows the required external wiring of terminal block X5.

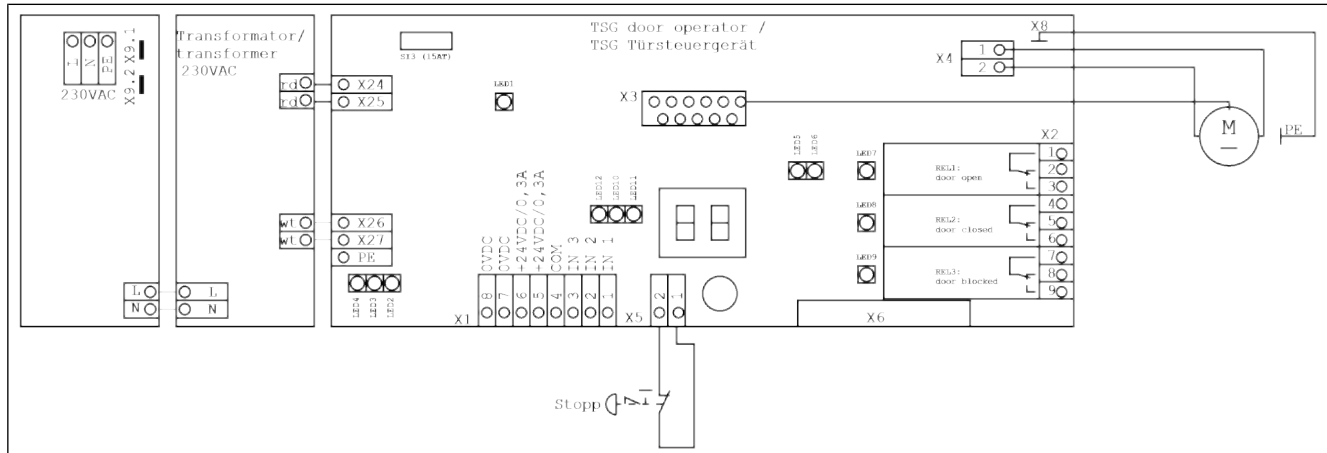

III. 23: Example stop function wiring

If the connection between terminals 1 and 2 of terminal block X5 is opened, the motor coasts to a stop. "FF" appears in the display.

After restoring the connection, the TSG V4 restarts in normal mode.

6.9.4 Leading limit switch

The output signals for “Door open” and “Door closed” (terminal block X2) can be set to be leading. In keeping with the configuration, they switch before the teached-in end position has been completely reached. The door drive continues moving the door until the teached-in end position has been completely reached, even if the input signal recedes. Any connected protective device within the set area is disregarded.

The following table shows which leading is achieved with which setting of the parameter **h2**.

Parameter h2	Leading		Parameter h2	Leading	
	Door open [cm]	Door closed [cm]		Door open [cm]	Door closed [cm]
00	0	0	16	3	3
01	0	0	17	5	0
02	0	1	18	10	0
03	1	0	19	15	0
04	1	1	20	0	5
05	0	2	21	5	5
06	2	0	22	10	5
07	1	2	23	15	5
08	2	1	24	0	10
09	2	2	25	5	10
10	0	3	26	10	10
11	3	0	27	15	10
12	1	3	28	0	15
13	3	1	29	5	15
14	2	3	30	10	15
15	3	2	31	15	15

6.9.5 Mechanical transmission

6.9.5.1 Description

This section applies to the TSG V4 software version V4.60.12 and higher

A fixed set gear transmission ratio is stored in the default setting in the TSG V4. However, in several applications, speed increases or reductions are desired. A changed mechanical transmission causes the forces, the speeds and the accelerations to be different to those expected. To level out the difference, the existing mechanical transmission can be adjusted in TSG V4.

6.9.5.2 Parameter

To set a changed mechanical transmission, the parameters **A8** and **A9** must be adjusted accordingly.

Par.	Function	Note	Min.	Standard	Max.	Factor	Unit
A8	Additional mechanical transmission		0.5	1.0	8.0		
A9	Release of the parameter A8		00	00	01		
CC	Ext the current level of the menu.						

When the parameter **A8** is changed and released by parameter **A9**, all speed, acceleration and braking parameters are automatically changed accordingly.

When the default settings are loaded, parameters **A8** and **A9** are not reset to the defaults.

When the default settings are loaded, all speed, acceleration and braking parameters are changed depending on the set mechanical transmission.

6.9.5.3 Example

If the mechanical layout differs from the standard layout, a different mechanical transmission exists.

Sequence

1. Commission the system with a measurement process.
2. Determine the transmission to be set.
 - Read off the measured door width from the TSG web interface or in the parameters **r6** to **r8**. **Example:** 5.0 m
 - Measure the existing door width manually (from end stop to end stop, not including the width of the door panel adapter). **Example:** 2.0 m
 - Calculate the transmission: transmission = door width in the TSG / real door width. **Example:** 5.0 m/2.0 m = 2.5
3. Enter the calculated transition in the parameter **A8**. **Example:** **A8** = 2.5
4. Activate the changed transmission with the parameter **A9** = 01.
 - ➡ The TSG updates the internal travel data based on the new transmission.

7 Operation

7.1 Restart after power failure and restored utility power

After a power failure and utility power recovery, the TSG V4 checks the teached-in positions (reference journey). To do so, the TSG V4 moves with reduced speed until both end positions are reached and detected. This speed can be set with the parameter **h6**.

The travel must be free of obstacles during the reference journey. If this is not the case, the obstacle is detected and is output in the display of the TSG V4 electronics "E 7" (see also ▶ [Error codes \(E parameters\) \[p. 55\]](#)). The referencing then begins again.

7.2 Normal operation

In normal operation the TSG V4 works automatically according to the set parameters.

8 Maintenance

8.1 Maintenance safety instructions

DANGER



Danger of death from electric shock

Dangerously high electric voltages can be applied to the cables and terminals.

- Work on electrical components may only be carried out by electrically qualified employees.
- Before starting any work on the electrical components, complete the five electrical safety steps:
 - Disconnect completely
 - Secure against reconnection
 - Verify that the installation is dead
 - Carry out earthing and short-circuiting
 - Provide protection against adjacent live parts

WARNING



Risk of injury from moving parts

Error and problem solving (troubleshooting) and maintenance and repair work that is carried out by unauthorized or unqualified employees can lead to serious accidents due to their lack of relevant technical knowledge and skills. Moving parts can cause injury.

- Wear the specified personal protective equipment.
- Allow authorized qualified employees of Langer & Laumann only to correct errors and solve problems.
- Allow Langer & Laumann only to set, repair or replace safety-related components.
- If you have any questions or problems, contact the customer service of Langer & Laumann.

CAUTION



Risk of burning on the motor

The motor of the TSG V4 can get very hot in continuous operation, thus causing a risk of burns.

- Allow the motor to cool before starting the work.
- Wear the specified personal protective equipment (suitable protective gloves).

8.2 Regular checks

The following checks must be carried out at regular intervals, however, at least every three months:

1. Check the doors, the drives and the electronics for identifiable damage and defects.
2. Check the easy movement of the door.
3. Check the synchronous belt for wear and mechanical tension.
4. Check the function of the elevator system (safety devices, inputs and outputs).
5. After completing the checks, restart all protective and safety devices.

If damage and/or defects are found, the elevator system must be taken out of service immediately. All damage and defects must be removed before renewed commissioning.

9 Troubleshooting

9.1 Troubleshooting safety instructions

DANGER



Danger of death from electric shock

Dangerously high electric voltages can be applied to the cables and terminals.

- Work on electrical components may only be carried out by electrically qualified employees.
- Before starting any work on the electrical components, complete the five electrical safety steps:
 - Disconnect completely
 - Secure against reconnection
 - Verify that the installation is dead
 - Carry out earthing and short-circuiting
 - Provide protection against adjacent live parts

WARNING



Risk of injury from moving parts

Error and problem solving (troubleshooting) and maintenance and repair work that is carried out by unauthorized or unqualified employees can lead to serious accidents due to their lack of relevant technical knowledge and skills. Moving parts can cause injury.

- Wear the specified personal protective equipment.
- Allow authorized qualified employees of Langer & Laumann only to correct errors and solve problems.
- Allow Langer & Laumann only to set, repair or replace safety-related components.
- If you have any questions or problems, contact the customer service of Langer & Laumann.

CAUTION



Risk of burning on the motor

The motor of the TSG V4 can get very hot in continuous operation, thus causing a risk of burns.

- Allow the motor to cool before starting the work.
- Wear the specified personal protective equipment (suitable protective gloves).

9.2 Error with displayed error code

If the TSG V4 electronics detect an error, an error code appears on the display (see also ▶ [Error codes \(E parameters\) \[p. 55\]](#)). The following table lists possible causes and troubleshooting actions for each error code.

Par.	Function	Meaning	Possible cause	Remedy
E0	Travel not limited	The door is outside the taught-in door distance by at least 5 cm.	Synchronous belt tension has changed.	Tighten the synchronous belt. Start measuring journey. ¹
			Travel incorrectly measured.	Start measuring journey. ¹
			Door mechanics have been changed.	Check the mechanics. Start measuring journey. ¹
			No defined end stops available.	Retrofit end stops on the car. Start measuring journey. ¹
E1	Travel disabled	<p>The door does not move. This error occurs <u>outside</u> the area of the blocked detection. The blocked detection is set <u>within</u> the area of the blocked detection and "bL" appears in the display.</p> <p>The current door travel is shorter than the door width taught-in during the set-up. This error resets itself after 15 seconds. During this time, the door drive does not respond to input signals at X1. If input signals exist at X1, the door drive starts with a reference journey with slow speed.</p>	Synchronous belt tension has changed.	Tighten the synchronous belt. Start measuring journey. ¹
			Landing door limits the travel.	Uncouple the landing door from the cabin door. Start measuring journey. ¹
			Blocking occurs within the area in which the blocked detection is switched off.	Check the door travel.
			The door is blocked at least three times consecutively during the opening.	Check the door travel.
			The door is blocked at least ten times consecutively during the closing.	Check the door travel.
			Door lock has not unlocked.	Check the mechanics of the door.
			Door measuring journey was faulty or was not carried out.	Start measuring journey. ¹
			E2	EEPROM error
E3	Blocked on reversing	The door drive has detected an obstacle and reverses. The door was also blocked on reversing.	There is an obstacle in the door.	Check the door travel.
		The door drive reverses due to the triggering of the external sensor. The door was also blocked on reversing.		
		The door drive has detected an obstacle in the opening direction and reverses. During the reversing the external sensor also triggers.		

Par.	Function	Meaning	Possible cause	Remedy
E4	Encoder signals not clear or not available	The encoder (encoder at the motor) does not send any values to the TSG V4.	Display of E4 flashes fast and regularly: cable to the encoder is not connected.	Connect cable to the encoder.
			Display of E4 flashes fast and regularly: cable to the encoder is damaged.	Replace the cable to the encoder.
			Display of E4 flashes fast and regularly: cable to the motor is not connected.	Connect cable to the motor.
			Display of E4 flashes fast and regularly: Cable to the motor is damaged.	Replace the cable to the motor or the motor.
			Display of E4 flashes on for 0.5, off for 1.5 seconds: motor connection cores are twisted.	Test motor protection cores and correct the connection.
			Display of E4 flashes on for 0.5 seconds, off for 1.5 seconds: encoder connection cores are twisted.	Check the encoder connection cores and correct connection.
			Display of E4 flashes on for 1.0 seconds, off for 1.0 seconds: end stage is defective.	TSG V4-Replace electronics.
			Wrong operating voltage.	Check operating voltage and correct if necessary.
E5	Current sensor monitoring triggered	The monitoring of the current sensor has triggered.	Cable to the motor damaged.	Replace the cable to the motor or the motor.
			Current sensor is defective.	TSG V4-Replace electronics.
			Wrong operating voltage.	Check operating voltage and correct if necessary.
			CPU, RAM or ROM is defective.	TSG V4-Replace electronics.

Par.	Function	Meaning	Possible cause	Remedy
E6	TSG internal monitoring	Check CPU, RAM and ROM.	RAM triggered.	TSG V4-Replace electronics.
			Display of E6 flashes on for 1.5 seconds, off for 0.5 seconds: run time monitoring has triggered.	
			Display of E6 flashes on for 1.0 seconds, off for 1.0 seconds: timing monitoring has triggered.	
			Display of E6 flashes on for 0.5 seconds, off for 1.5 seconds: ROM has triggered.	
E7	Blocked after switching back on	Door was blocked after utility power restored.	After the TSG V4 is switched on again or an error has occurred, the door must rereference itself. If the door is blocked during this travel the error is triggered. The door mechanics have been changed, but the TSG V4 has not been taught-in again.	Check the mechanics. Start measuring journey. ¹
E8	Number of restarts	Counter for the number of utility power starts.	Utility power has failed, the TSG V4 electronics carry out a restart.	Check supply cable.
				Check backup fuse.
				Check fuse on the TSG V4 electronics.
				If necessary, replace TSG V4 electronics.
E9	Monitoring of stop input, end stage, self-diagnosis		End stage is defective.	TSG V4-Replace electronics.
			Set parameter is incorrect.	Check parameter and change if necessary.
EA	Overcurrent in standstill	The connected motor draws too much current.	End stage is defective.	TSG V4-Replace electronics.
			Current sensor is defective.	TSG V4-Replace electronics.

Par.	Function	Meaning	Possible cause	Remedy
Eb	Voltage error	The various operating voltages on the TSG V4 electronics are monitored and evaluated. An error has occurred.	5 V not ok.	TSG V4-Replace electronics.
			Eb display flashes on for 0.5 seconds, off for 1.5 seconds: 12 V not ok.	
			Eb display flashes on for 1.0 seconds, off for 1.0 seconds: 24 V not ok.	
			Eb display flashes on for 1.5 seconds, off for 0.5 seconds: 38 V not ok.	
EC	Motor is faulty	The connected motor is damaged.	An incorrect motor is connected.	Replace the motor.
			Cable to the motor damaged.	Replace the cable to the motor or the motor.
			Operating voltage too low.	Check the operating voltage and correct if necessary.
Ed	Motor detection is faulty		The motor is not detected by the cable to the encoder.	Test the cable to the encoder and start the measuring journey. ¹
			Short circuit in encoder connector.	Test the encoder connector and start measuring journey. ¹
EH	Temporary warning message: Motor is faulty. The EH display is only shown as long as the error is queued. No error counter is stored, a read-out is not possible.	The internal resistance of the motor is higher than expected.	The connected motor is damaged.	Replace the motor.
			The cable to the motor is too long.	Check the wiring. If it has been lengthened, change it back.
			Operating voltage too low.	Check operating voltage and correct if necessary.
EL	Temporary warning message: Motor is faulty. The EL display is only shown as long as the error is queued. No error counter is stored, a read-out is not possible.		Cable to the motor damaged.	Replace the cable to the motor or the motor.
			Cable to the encoder is damaged.	Replace the cable to the encoder.
			Operating voltage too low.	Check operating voltage and correct if necessary.
En	CAN bus communication is interrupted or disturbed. The En display is only shown as long as the error is queued. No error counter is stored, a read-out is not possible.	The CAN bus connected to the additional circuit board is interrupted or faulty.		Check CAN bus cable and connections.
				Check CAN bus master.

Par.	Function	Meaning	Possible cause	Remedy
Eu	Additional communication circuit board is interrupted or faulty. The Eu display is only shown as long as the error is queued. No error counter is stored, a read-out is not possible.	Communication with the connected additional circuit board is interrupted or disrupted.	Flat ribbon cable not plugged in correctly or is defective.	Plug in flat ribbon cable or replace TSG V4 electronics.
			Wrong additional circuit board selected via the parameter hA .	Correct value in parameter hA .
			Additional circuit board is defective.	TSG V4-Replace electronics.
EE	Load default settings			
EF	Delete error counter			

1. See also ► [Door learning procedure \[p. 42\]](#).

Table 35: Meaning of the error codes for troubleshooting

9.3 Error without displayed error code

The following table contains information on errors for which an error code cannot be displayed when they occur.

Error	Possible cause	Remedy
Drive is not running.	TSG V4 is de-energized.	Switch on utility power. Check LED 1, LED 2, LED 3 and LED 4.

Table 36: Further possible causes of error

10 Dismantling and disposal

10.1 Dismantling and disposal safety instructions

DANGER



Danger of death from electric shock

Dangerously high electric voltages can be applied to the cables and terminals.

- Work on electrical components may only be carried out by electrically qualified employees.
- Before starting any work on the electrical components, complete the five electrical safety steps:
 - Disconnect completely
 - Secure against reconnection
 - Verify that the installation is dead
 - Carry out earthing and short-circuiting
 - Provide protection against adjacent live parts

CAUTION



Risk of burning on the motor

The motor of the TSG V4 can get very hot in continuous operation, thus causing a risk of burns.

- Allow the motor to cool before starting the work.
- Wear the specified personal protective equipment (suitable protective gloves).

ATTENTION

Risk of environmental damage

Handling and disposal of hazard substances such as lubricants and cleaning agents are subject to legal provisions. If operating supplies and lubricants are not disposed of properly, the environment can be damaged.

- Make sure that the operating supplies are disposed of properly.
- Do not mix waste oil that is produced with other substances or liquids.
- If you have any questions, contact the customer service of Langer & Lauermann.

10.2 Disposal

If a return or disposal agreement has not been concluded, recycle or reuse the dismantled parts:

1. Scrap metals.
2. Recycle plastic element.
3. Dispose of the other components according to their material properties.

If you have any questions, contact the customer service of Langer & Laumann.

Electronic components The following electronic components must be disposed of separately:

- Displays, display devices
- Electrical supply
- Controls
- Circuit boards with electronics

Used operating materials Detailed information on disposal of the lubricants used can be found in the safety data sheets of the lubricants and cleaning agents.

11 Declaration of incorporation

The original EC declaration of Incorporation for the TSG V4 is available on the internet: www.lul-ing.de

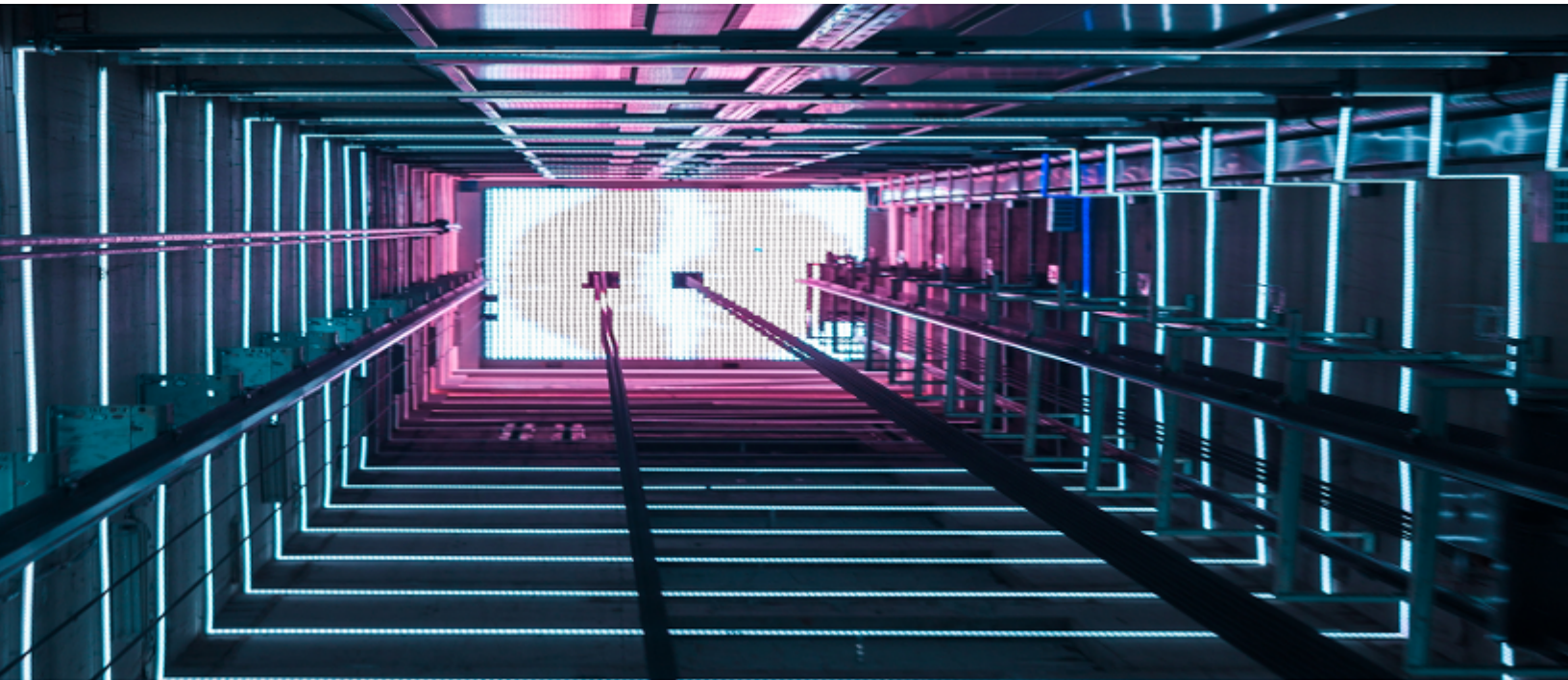

Innovation meets Technology

1.20.91000
V4.20
05.05.2025

